

# **Operating and Service Manual**

## **Agilent 8480 Series Coaxial Power Sensors**

**This manual applies to the following models:**

**8481A  
8482A  
8483A  
8485A  
8487A  
8481B  
8482B  
8481H  
8482H  
8487D  
8485D  
8481D**



**Agilent Technologies**

**Manufacturing Part Number: 08481-90173**

**May 2004**

© Copyright 2004 Agilent Technologies.

---

## Notice

The material contained in this document is provided "as is," and is subject to being changed, without notice, in future editions. Further, to the maximum extent permitted by applicable law, Agilent disclaims all warranties, either express or implied with regard to this manual and any information contained herein, including but not limited to the implied warranties of merchantability and fitness for a particular purpose. Agilent shall not be liable for errors or for incidental or consequential damages in connection with the furnishing, use, or performance of this document or any information contained herein. Should Agilent and the user have a separate written agreement with warranty terms covering the material in this document that conflict with these terms, the warranty terms in the separate agreement will control.

All Rights Reserved. Reproduction, adaptation, or translation without prior written permission is prohibited, except as allowed under the copyright laws.

1400 Fountaingrove Parkway, Santa Rosa CA, 95403-1799, USA

---

## Warranty

A copy of the specific warranty terms applicable to your Agilent Technologies product can be obtained from your local Sales and Service Office.

---

## Manufacturer's Declaration

This statement is provided to comply with the requirements of the German Sound Emission Directive, from 18 January 1991.

This product has a sound pressure emission (at the operator position) < 70 dB(A).

Diese Information steht im Zusammenhang mit den Anforderungen der Maschinenlärminformationsverordnung vom 18 Januar 1991.

- Sound Pressure  $L_p < 70$  dB(A).
- At Operator Position.
- Normal Operation.
- According to ISO 7779:1988/EN 27779:1991 (Type Test).
- Schalldruckpegel  $L_p < 70$  dB(A).
- Am Arbeitsplatz.
- Normaler Betrieb.
- Nach ISO 7779:1988/EN 27779:1991 (Typprüfung).

**Hersteller-  
bescheinigung**



---

# Contents

## 1. Introduction

General Information . . . . .	2
Instruments Covered by Manual . . . . .	2
Description . . . . .	3
Dimensions . . . . .	5
8480 series, B-models information . . . . .	5
Safety Considerations . . . . .	6
8480 series, Options . . . . .	6
8485A and 8485D option 033 . . . . .	6
Accessories Supplied . . . . .	6
8483A 75 ohm sensor . . . . .	7
D-model 8480 series sensors (8481D, 8485D, 8485D-033 and 8487D).7	
26.5 GHz and 33 GHz Frequency operation (8485A, 8485A-033, 8485D and 8485D-033) . . . . .	8
50 GHz Frequency operation (8487A and 8487D) . . . . .	9
Recommended Calibration Interval . . . . .	10
Warranty . . . . .	10
8480 Series Power Sensor Specifications . . . . .	11
Supplemental Characteristics . . . . .	18
Installation . . . . .	19
Initial Inspection . . . . .	19
Original Packaging . . . . .	19
Interconnections . . . . .	19
Storage and Shipment . . . . .	19
Environment . . . . .	19
Operation . . . . .	20
Environment . . . . .	20
Operating Precautions . . . . .	20
Power Meter Calibrations . . . . .	20
Operating Instructions . . . . .	21

---

# Contents

Power Measurements . . . . .	21
Modulation Effects . . . . .	21
<b>2. General Information</b>	
Recommended Test Equipment . . . . .	24
Connector Care . . . . .	25
Torque . . . . .	25
Performance Test . . . . .	26
Standing Wave Ratio (SWR) and Reflection Coefficient (Rho)	
Performance Test . . . . .	26
Replaceable Parts . . . . .	30
<b>3. Service</b>	
Principles of Operation . . . . .	36
Thermocouple Sensors . . . . .	36
Diode Sensors . . . . .	37
Troubleshooting . . . . .	39
Troubleshooting - Eliminating the Power Meter and Sensor Cable. .	40
Troubleshooting - Power Sensors . . . . .	40
A1 Bulkhead (Thermocouple Sensors) . . . . .	40
A1 Bulkhead (Diode Sensors) . . . . .	41
A2 Power Sensor Board Assembly . . . . .	42
Repair . . . . .	43
A1 Bulkhead Assembly . . . . .	43
Repair Strategy . . . . .	43
Procedure . . . . .	43
A2 Power Sensor Board Assembly . . . . .	44
Repair Strategy . . . . .	44
Procedure . . . . .	44

---

# Contents

FET Balance Adjustment . . . . .	45
Equipment Required . . . . .	45
Test Description . . . . .	45
FET Balance Procedure . . . . .	46
Disassembly / Reassembly Procedures . . . . .	49
Disassembly Procedure . . . . .	49
Reassembly Procedures . . . . .	51
<b>A. EPM Series Power Meter (E4418B) Modification</b>	
The Material and Tools Required . . . . .	54
Impact on Warranty . . . . .	54
Modification Procedure . . . . .	55
<b>B. Bulkhead Assemblies</b>	
Bulkhead Parts Lists . . . . .	62
Bulkhead Exploded Graphics . . . . .	69

---

# Contents



---

# **1 Introduction**

This Operating and Service Manual contains information about initial inspection, performance tests, adjustments, operation, troubleshooting and repair of the Agilent 8480 Series Coaxial Power Sensors.

## General Information

### Instruments Covered by Manual

A serial number label is attached to the power sensor. The serial number has two parts: the prefix (two letters and the first four numbers), and the suffix (the last four numbers). Refer to the Example Serial Number shown in Figure 1-1.

**Figure 1-1**      **Example Serial Number**

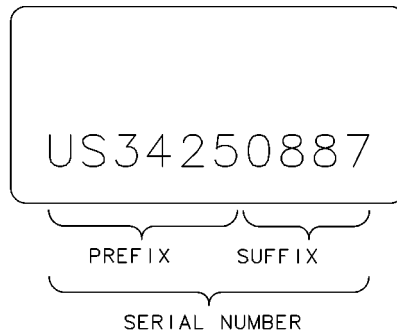

The two letters identify the country in which the unit was manufactured. "US" represents the USA and "MY" represents Malaysia. The four numbers of the prefix are a code identifying the date of a major design change incorporated in your power sensor. The four digit suffix is a sequential number and, coupled with the prefix, provides a unique identification for each unit produced.

When seeking information about your power sensor refer to the complete serial number and include the full prefix number and the suffix number.

For further information concerning a serial number, contact your nearest Agilent Technologies Sales and Service office.

## Description

The 8480 series power sensors are used for measuring the average power supplied by an RF or microwave source or device-under-test (DUT). In use, the Power Sensor is connected to the RF or microwave source and to a compatible power meter. Suitable and compatible power meters are the EPM series power meters (E4418B and E4419B), the EPM-P series power meters (E4416A and E4417A) and the E1416A VXI power meter. Discontinued and obsolete power meters that are compatible with the 8480 series sensors include the E4418A, E4419A, 435B, 436A, 437B, 438A and 70100A MMS power meter.

The 8480 series power sensors place a 50 ohm load on the RF or microwave source, except the 8483A which has a 75 ohm load. The power meter indicates the power dissipated in this load in mW or dBm.

The coaxial power sensors in the 8480 series measure power levels from -70 dBm to +44 dBm (100 pW to 25 W), at frequencies from 100 kHz to 50 GHz. To cover this wide dynamic power range, both thermocouple and diode power sensing elements are used. Both types of power sensing elements have a maximum 50 dB dynamic range. Thermocouple sensors have a square-law region from -30 dBm to +20 dBm, and with an attenuator can operate up to +44 dBm. There are three model types of thermocouple sensors in the 8480 series, covering the complete -30 dBm to +44 dBm range.

- The A-models cover -30 dBm to +20 dBm.
- The H-models cover from -10 dBm to +35 dBm.
- The B-models cover from 0 dBm to +44 dBm.

Diode detectors (D-models) have the best sensitivity, having an operating range from -70 dBm to -20 dBm.

Calibration factor (CAL FACTOR) data is provided on a label attached to the power sensor's cover. Maximum uncertainties of the CAL FACTOR data are listed in the Specifications section in page 11. This calibration factor is used to adjust the power meter to suit the particular power sensor and frequency being measured.

---

### NOTE

For the B-models in the 8480 series, calibration factor data is valid only when the sensor is used with the supplied attenuator.

---

**Figure 1-2**      **8480 Series Power Sensor Simplified Block Diagram**

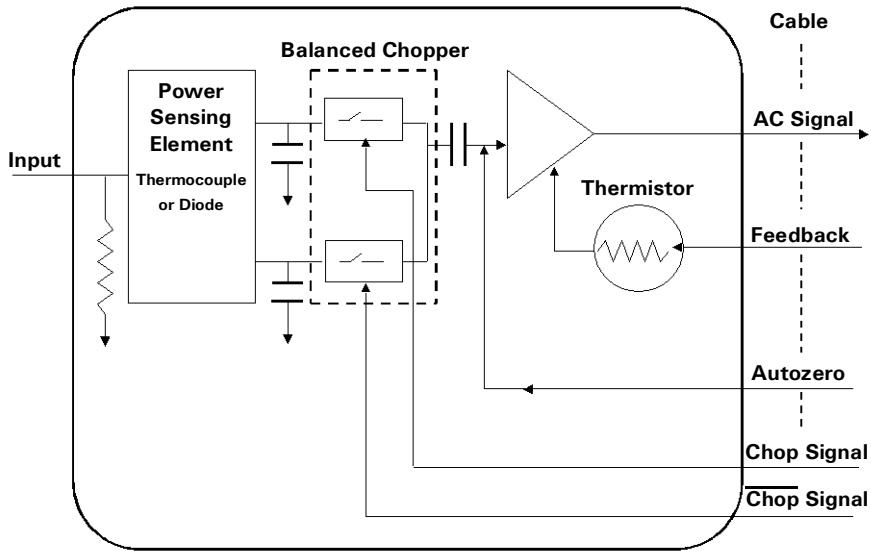

Figure 1-2 shows a basic power sensor block diagram for both thermocouple and diode power sensing elements. From the RF or microwave signal input, both thermocouple and diode detector mounts generate very low voltages, (on the order of nV or  $\mu\text{V}$ ). The dc voltage is proportional to the power from the RF or microwave source. As the dc voltage is a very low-level, it requires amplification before it can be transferred to the power meter on the standard cables.

The amplification is provided by an input amplifier assembly that consists of a balanced chopper (sampling gate) and an AC coupled low-noise amplifier. The dc voltage is routed on gold wires to the chopper circuit, which converts the low-level dc voltage to an ac voltage. To do this, the chopper is uses two field effect transistors (FET's) controlled by a 220 Hz square-wave generated by in the power meter (the Chop Signal). The result is an ac output signal proportional to the dc input. The ac signal is then amplified to a relatively high-level ac signal that can be routed to the power meter by standard cables.

The autozero signal removes residual error voltages when there is no input RF or microwave power connected to the sensor input, and temperature compensation is provided by a thermistor located in amplifier feedback path.

## Dimensions

The physical dimensions of the power sensors differ in the model types. This is due to the additional attenuation used to obtain the high power performance.

**Table 1-1 8480 Series Power Sensor Dimensions (including the RF Connector)**

8480 series power sensor models	Dimensions
A-models	<p><b>8481A, 8482A and 8483A:</b> 38 mm wide, 30 mm high, 105 mm long (1.5 in. x 1.2 in. x 4.1 in)</p> <p><b>8485A and 8487A:</b> 38 mm wide, 30 mm high, 95 mm long (1.5 in. x 1.25 in. x 3.75 in.)</p>
B-models	83 mm x 114 mm x 248 mm (approx. 3.25 in. x 4.50 in. x 9.75 in.)
D-models	<p><b>8481D and 8485D:</b> 38 mm wide, 30 mm high, 102 mm long (1.5 in. x 1.2 in. x 4.02 in)</p> <p><b>8487D:</b> 38 mm wide, 30 mm high, 94 mm long (1.5 in. x 1.2 in. x 3.7 in)</p>
H-models	38 mm wide, 30 mm high, 149 mm long (1.5 in. x 1.2 in. x 5.9 in)

---

### CAUTION

Do not disassemble the power sensor. The 8480 series power sensors are static sensitive and can be easily damaged.

---

## 8480 series, B-models information

The 25 W (+44 dBm) power sensor is a calibrated combination of a 30 dB, 25 W attenuator assembly and a sensor assembly. The attenuator and sensor assemblies are calibrated as a set and must be used together if specified accuracies are to be obtained.

This combination is referred to as the power sensor.

---

**CAUTION**

Removal of the D-ring that is on the sensor assembly WILL VOID THE WARRANTY. The input connector on the sensor has a D-ring to prevent the sensor from being connected to a high power source when its attenuator is not attached. The sensor must only be connected to the power meter for calibration or to the high power attenuator for RF measurement.

---

**Safety Considerations**

The warning that follows is related to possible personal injury.

---

**WARNING**

**The high power attenuator contains a substrate of beryllium oxide. Beryllium oxide in a powder form is a hazardous material and may be injurious to your health if inhaled. Do not perform any operation on the beryllium oxide that might generate dust. Defective attenuator should be returned to Agilent Technologies for proper disposal.**

---

**8480 series, Options**

**8485A and 8485D option 033**

The 8485A and 8485D power sensors with option 033 are calibrated to measure power levels in the 50 MHz to 33 GHz frequency range. In all other respects, they are the same as their respective standard power sensor.

**Accessories Supplied**

Accessories are required to connect various power sensors to the power meter's 50 ohm, Power Reference (1 mW, 50 MHz) output connector (Type-N (f)).

### 8483A 75 ohm sensor

The 8483A sensor is supplied with an adapter, shown in Figure 1-3. This accessory is a mechanical adapter only, not an impedance transformer, therefore an impedance mismatch exists that must be taken into consideration when calibrating the power meter and sensor. The REF CAL FACTOR, on the power sensor label, has been adjusted for the impedance mismatch. This REF CAL FACTOR, when used to calibrate any power meter, will allow calibration to 1.000 mW. The CAL FACTOR, from the data on the sensor label, should be used for any power measurements in a 75 ohm system at 50 MHz.

---

**CAUTION**

Remove the mechanical adapter from the power sensor before connecting the sensor to a 75 ohm source.

---

**Figure 1-3**

**Mechanical Adapter (8483A Only)**

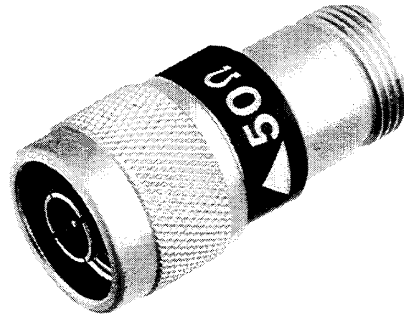

### D-model 8480 series sensors (8481D, 8485D, 8485D-033 and 8487D)

D-model sensors are supplied with a 11708A 30 dB attenuator. To calibrate a D-model sensor, the 1 mW 50 MHz Power Reference supplied by the power meter must be reduced to 1 $\mu$ W. The reference attenuator provides the means to do this.

**Table 1-2 11708A 30 dB attenuator characteristics**

Characteristic	Limits	Comments
11708A accuracy at 50 MHz, 25 °C	30 ± 0.05 dB	Accuracy traceable to National Institute of Standards and Technology (NIST), with a temperature coefficient typically 0.003 dB per °C.
Dimensions	Length: 60 mm (2.4 in) Diameter: 20 mm (0.8 in)	

---

**NOTE**

The 11708A 30 dB attenuator is intended for use only at the 1 mW, 50 MHz power reference of the power meter. Its function as a calibration reference may be compromised if used for other purposes.

---

**26.5 GHz and 33 GHz Frequency operation (8485A, 8485A-033, 8485D and 8485D-033)**

8480 series sensors that operate up to 26.5 GHz and 33 GHz are fitted with APC-3.5mm (m) connectors as standard. To convert the APC-3.5mm (m) connector for calibration an adapter (APC-3.5 (f) to Type-N (m)) is included with the power sensors. Figure 1-4 shows the parts included with your power sensor.

---

**NOTE**

The APC-3.5mm to Type-N adapter is intended for use only at the 1 mW, 50 MHz power reference of the power meter. Its function as a calibration reference may be compromised if used for other purposes.

---



**Figure 1-4 8485A, 8485A-033, 8485D, 8485D-033 Sensor Accessories**



#### **50 GHz Frequency operation (8487A and 8487D)**

8480 series sensors that operate up to 50 GHz are fitted with 2.4mm (m) connectors as standard. To convert the 2.4mm (m) connector for calibration, adapter (2.4mm (f) to Type-N (m)) is included with the power sensors (shown in Figure 1-5).

---

#### **NOTE**

The 2.4mm to Type-N adapter is intended for use only at the 1 mW, 50 MHz power reference of the power meter. Its function as a calibration reference may be compromised if used for other purposes.

---

**Figure 1-5** 8487A Power Sensor with Adapter



## Recommended Calibration Interval

Agilent Technologies recommends a one-year calibration cycle for the 8480 series power sensors.

## Warranty

The 8480 series power sensors described in this manual are warranted and certified as indicated on the inside cover of this manual. Power sensors are warranted only when they are operated within their specifications, especially the maximum power handling capability. Any power sensor returned to Agilent Technologies under warranty will be examined carefully to determine if the failure was possibly due to improper use.

Do not open the power sensor. Any attempt to disassemble the power sensor will void the warranty.

---

## 8480 Series Power Sensor Specifications

---

**NOTE** These specifications are valid with EPM and EPM-P Series of power meters.

---

The 8480 series thermocouple and diode power sensors provide accuracy, stability, and SWR over a wide range of frequencies (100 kHz to 50 GHz) and power levels (-70 dBm to +44 dBm)

---

**NOTE** Both Table 1-3 and Table 1-4 show typical uncertainty values to help estimate measurement uncertainty. These values are only a guideline, and are not to be used in any accurate uncertainty calculations. Refer to your power sensor's specific calibration report for accurate values.

---

**Table 1-3 Typical root sum of squares (rss) uncertainty on the calibration factor data printed on the power sensor**

Freq (MHz)	8482A	8482B	8482H	8483A
0.1	0.8	1.5	0.8	1.3
0.3	0.7	1.4	0.9	1.2
1	0.7	1.4	0.9	1.1
3	0.8	1.5	0.8	1.2
10	0.8	1.5	0.8	1.2
30	0.8	1.5	0.9	1.2
50	0.7	1.4	0.8	1.2
100	0.8	1.4	0.8	1.2
300	0.8	1.4	0.8	1.2
1000	0.8	1.5	0.9	1.2
2000	0.8	1.5	0.8	1.2
4000	0.9	1.5	0.9	-

Introduction  
**8480 Series Power Sensor Specifications**

**Table 1-4 Typical root sum of squares (rss) uncertainty on the calibration factor data printed on the power sensor**

Freq (GHz)	8481A	8481B	8481H	8481D	8485A	8485D	8487A	8487D
1	0.7	1.4	0.8	0.8	1.4	1.4	1.4	1.3
2	0.7	1.4	0.8	0.8	1.4	1.4	1.4	1.3
4	0.8	1.5	0.8	0.8	1.7	1.7	1.4	1.4
6	0.9	1.5	0.9	0.9	1.7	1.7	1.5	1.4
8	1.0	1.5	1.0	1.0	1.7	1.7	1.5	1.4
10	1.0	1.6	1.0	1.1	1.9	1.9	1.5	1.5
12	1.1	1.6	1.1	1.2	1.9	1.9	1.6	1.5
14	1.2	1.6	1.2	1.1	2.0	2.0	1.6	1.6
16	1.2	1.7	1.2	1.5	2.0	2.1	1.7	1.7
18	1.5	1.9	1.5	1.7	2.1	2.2	1.7	1.7
22	-	-	-	-	2.6	2.7	1.9	1.9
26.5	-	-	-	-	2.8	2.8	2.1	2.2
28	-	-	-	-	3.1 <sup>a</sup>	2.9 <sup>a</sup>	2.2	2.3
30	-	-	-	-	3.2 <sup>a</sup>	3.2 <sup>a</sup>	2.3	2.4
33	-	-	-	-	3.7 <sup>a</sup>	3.3 <sup>a</sup>	2.3	2.6
34.5	-	-	-	-	-	-	2.3	2.6
37	-	-	-	-	-	-	2.4	2.7
40	-	-	-	-	-	-	2.5	3.0
42	-	-	-	-	-	-	2.6	3.2
44	-	-	-	-	-	-	2.9	3.5
46	-	-	-	-	-	-	3.1	3.8
48	-	-	-	-	-	-	2.9	3.8
50	-	-	-	-	-	-	3.8	5.0

a. These uncertainties only apply to Option 033.

**Table 1-5 25 Watt sensors, 1 mW to 25 W (0 dBm to +44 dBm)**

Model	Frequency Range	Maximum SWR	Power Linearity <sup>a</sup>	Maximum Power	Connector Type	Weight
8481B	10 MHz to 18 GHz	10 MHz to 2 GHz: <b>1.10</b> 2 GHz to 12.4 GHz: <b>1.18</b> 12.4 GHz to 18 GHz: <b>1.28</b>	+35 dBm to +44 dBm: $\pm 4\%$	0°C to 35°C: 30W avg <sup>b</sup> 35°C to 55°C: 25W avg 0.01 to 5.8 GHz: 500W pk 5.8 to 18 GHz: 125W pk 500W, $\mu$ s / pulse	Type-N(m)	Net: 0.8 kg (1.75 lb) Shipping: 1.5 kg (3.25 lb)
8482B	100 kHz to 4.2 GHz	100 kHz to 2 GHz: <b>1.10</b> 2 GHz to 4.2 GHz: <b>1.18</b>	+35 dBm to +44 dBm: $\pm 4\%$	0°C to 35°C: 30W avg <sup>b</sup> 35°C to 55°C: 25W avg 0.1 to 4,2 GHz: 500W pk 500W, $\mu$ s / pulse	Type-N(m)	Net: 0.8 kg (1.75 lb) Shipping: 1.5 kg (3.25 lb)

a. Negligible deviation except for those power ranges noted.

b. For pulses greater than 30 W, the maximum average power (Pa) is limited by the energy per pulse (E) in W, $\mu$ s according to  $P_a = 30 - 0.02 E$ .

**Table 1-6 3 Watt sensors, 100  $\mu$ W to 3 W (-10 dBm to +35 dBm)**

Model	Frequency Range	Maximum SWR	Power Linearity <sup>a</sup>	Maximum Power	Connector Type	Weight
8481H	10 MHz to 18 GHz	10 MHz to 8 GHz: <b>1.20</b> 8 GHz to 12.4 GHz: <b>1.25</b> 12.4 GHz to 18 GHz: <b>1.30</b>	+25 dBm to +35 dBm: $\pm 5\%$	3.5W avg, 100W pk 100W, $\mu$ s / pulse	Type-N(m)	Net: 0.2 kg (0.38 lb) Shipping: 0.5 kg (1.0 lb)
8482H	100 kHz to 4.2 GHz	100 kHz to 4.2 GHz: <b>1.20</b>	+25 dBm to +35 dBm: $\pm 5\%$	3.5W avg, 100W pk 100W, $\mu$ s / pulse	Type-N(m)	Net: 0.2 kg (0.38 lb) Shipping: 0.5 kg (1.0 lb)

a. Negligible deviation except for those power ranges noted.

## 8480 Series Power Sensor Specifications

Table 1-7 100 mW sensors, 1  $\mu$ W to 100 mW (-30 dBm to +20 dBm)

Model	Frequency Range	Maximum SWR	Power Linearity <sup>a</sup>	Maximum Power	Connector Type	Weight
8485A	50 MHz to 26.5 GHz	50 MHz to 100 MHz: <b>1.15</b> 100 MHz to 2 GHz: <b>1.10</b> 2 GHz to 12.4 GHz: <b>1.15</b> 12.4 GHz to 18 GHz: <b>1.20</b> 18 GHz to 26.5 GHz: <b>1.25</b>	+10 dBm to +20 dBm: $\pm 3\%$	300 mW avg, 15 W pk 30 W, $\mu$ s / pulse	APC - 3.5mm(m)	Net: 0.2 kg (0.38 lb) Shipping: 0.5 kg (1.0 lb)
Option 8485A -033	26.5 MHz to 33 GHz	26.5 GHz to 33 GHz: <b>1.40</b>	+10 dBm to +20 dBm: $\pm 3\%$	300 mW avg, 15 W pk 30 W, $\mu$ s / pulse	APC - 3.5mm(m)	Net: 0.2 kg (0.38 lb) Shipping: 0.5 kg (1.0 lb)
8481A	10 MHz to 18 GHz	10 MHz to 30 MHz: <b>1.40</b> 30 MHz to 50 MHz: <b>1.18</b> 50 MHz to 2 GHz: <b>1.10</b> 2 GHz to 12.4 GHz: <b>1.18</b> 12.4 GHz to 18 GHz: <b>1.28</b>	+10 dBm to +20 dBm: $\pm 3\%$	300 mW avg, 15 W pk 30 W, $\mu$ s / pulse	Type-N(m)	Net: 0.2 kg (0.38 lb) Shipping: 0.5 kg (1.0 lb)
8482A	100 kHz to 4.2 GHz	100 kHz to 300 kHz: <b>1.60</b> 300 kHz to 1 MHz: <b>1.20</b> 1 MHz to 2 GHz: <b>1.10</b> 2 GHz to 4.2 GHz: <b>1.30</b>	+10 dBm to +20 dBm: $\pm 3\%$	300 mW avg, 15W pk 30 W, $\mu$ s / pulse	Type-N(m)	Net: 0.2 kg (0.38 lb) Shipping: 0.5 kg (1.0 lb)

**Table 1-7                    100 mW sensors, 1  $\mu$ W to 100 mW (-30 dBm to +20 dBm)**

Model	Frequency Range	Maximum SWR	Power Linearity <sup>a</sup>	Maximum Power	Connector Type	Weight
8483A (75ohm)	100 kHz to 2 GHz	100 kHz to 600 kHz: <b>1.80</b> 600 kHz to 2 GHz: <b>1.18</b>	+10 dBm to +20 dBm: $\pm 3\%$	300 mW avg, 10W pk	Type-N(m) (75 ohm)	Net: 0.2 kg (0.38 lb) Shipping: 0.5 kg (1.0 lb)
8487A	50 MHz to 50 GHz	50 MHz to 100 MHz: <b>1.15</b> 100 MHz to 2 GHz: <b>1.10</b> 2 GHz to 12.4 GHz: <b>1.15</b> 12.4 GHz to 18 GHz: <b>1.20</b> 18 GHz to 26.5 GHz: <b>1.25</b> 26.5 GHz to 40 GHz: <b>1.30</b> 40 GHz to 50 GHz: <b>1.50</b>	+10 dBm to +20 dBm: $\pm 3\%$	300 mW avg, 15W pk 30 W, $\mu$ s / pulse	2.4 mm (m)	Net: 0.14 kg (0.28 lb) Shipping: 0.5 kg (1.0 lb)

a. Negligible deviation except for those power ranges noted.

## 8480 Series Power Sensor Specifications

**Table 1-8 High sensitivity sensors, 100 pW to 10  $\mu$ W (-70 dBm to -20 dBm)**

Model	Frequency Range	Maximum SWR	Power Linearity <sup>a</sup>	Maximum Power	Connector Type	Weight
8481D <sup>b</sup>	10 MHz to 18 GHz	10 MHz to 30 MHz: <b>1.40</b> 30 MHz to 4 GHz: <b>1.15</b> 4 GHz to 10 GHz: <b>1.20</b> 10 GHz to 15 GHz: <b>1.30</b> 15 GHz to 18 GHz: <b>1.35</b>	-30 dBm to -20 dBm: $\pm 1\%$	100 mW avg, 100 mW pk	Type-N (m)	Net: 0.16 kg (0.37 lb) Shipping: 0.5 kg (1.0 lb)
8485D <sup>b</sup>	50 MHz to 26.5 GHz	50 MHz to 100 MHz: <b>1.19</b> 100 MHz to 4 GHz: <b>1.15</b> 4 GHz to 12 GHz: <b>1.19</b> 12 GHz to 18 GHz: <b>1.25</b> 18 GHz to 26.5 GHz: <b>1.29</b>	-30 dBm to -20 dBm: $\pm 2\%$	100 mW avg, 100 mW pk	APC - 3.5mm (m)	Net: 0.2 kg (0.38 lb) Shipping: 0.5 kg (1.0 lb)
Option 8485D-033	50 MHz to 33 GHz	26.5 GHz to 33 GHz: <b>1.35</b>	-30 dBm to -20 dBm: $\pm 2\%$	100 mW avg, 100 mW pk	APC - 3.5mm (m)	Net: 0.2 kg (0.38 lb) Shipping: 0.5 kg (1.0 lb)



**Table 1-8 High sensitivity sensors, 100 pW to 10  $\mu$ W (-70 dBm to -20 dBm)**

Model	Frequency Range	Maximum SWR	Power Linearity <sup>a</sup>	Maximum Power	Connector Type	Weight
8487D <sup>b</sup>	50 MHz to 50 GHz	50 MHz to 100 MHz: <b>1.19</b> 100 MHz to 2 GHz: <b>1.15</b> 2 GHz to 12.4 GHz: <b>1.20</b> 12.4 GHz to 18 GHz: <b>1.29</b> 18 GHz to 34 GHz: <b>1.37</b> 34 GHz to 40 GHz: <b>1.61</b> 40 GHz to 50 GHz: <b>1.89</b>	-30 dBm to -20 dBm: $\pm 2\%$	100 mW avg, 100 mW pk 10 W, $\mu$ s / pulse	2.4 mm (m)	Net: 0.2 kg (0.38 lb) Shipping: 0.5 kg (1.0 lb)

- a. Negligible deviation except for those power ranges noted.
- b. Includes 11708A 30 dB attenuator for calibrating against 0 dBm, 50 MHz power reference. The 11708A is factory set to 30 dB  $\pm 0.05$  dB at 50 MHz, traceable to NIST. SWR < 1.05 at 50 MHz.

## Supplemental Characteristics

Supplemental characteristics are intended to provide additional information, useful in applying the power sensor by giving typical (expected) but not warranted performance parameters.

**Figure 1-6** Typical CAL FACTOR and SWR vs. Frequency

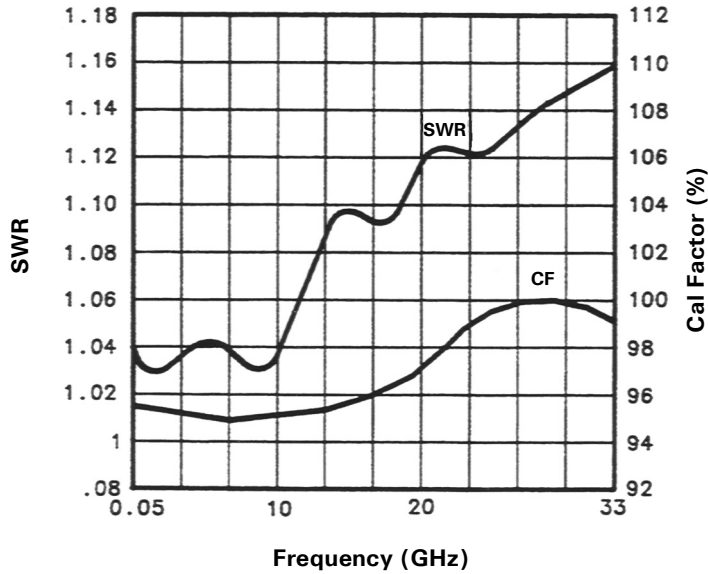

---

## Installation

### Initial Inspection

Inspect the shipping container. If the container or packing material is damaged, it should be kept until the contents of the shipment have been checked mechanically and electrically. If there is mechanical damage or if the instrument does not pass the performance tests, notify the nearest Agilent Technologies office. Keep the damaged shipping materials (if any) for inspection by the carrier and an Agilent Technologies representative.

### Original Packaging

Containers and materials identical to those used in factory packaging are available through Agilent Technologies' offices. If the instrument is being returned to Agilent Technologies for servicing, attach a tag indicating the type of service required, return address, model number, and serial number. Also, mark the container FRAGILE to assure careful handling. In any correspondence, refer to the instrument by model number and serial number.

### Interconnections

Refer to the power meter's User's Guide for interconnecting instructions.

### Storage and Shipment

#### Environment

The instrument should be stored in a clean, dry environment. The following limitations apply to both storage and shipment:

Temperature	- 40 to +75°C
Relative humidity	<95%
Altitude	< 7,600 metres (25,000 ft.)

## Operation

### Environment

The operating environment for the Power Sensor should be as follows:

Temperature	0 to +55°C
Relative humidity	<95%
Altitude	< 4,572 metres (15,000 ft.)

### Operating Precautions

Before the Power Sensor is connected, the following precautions must be observed.

---

#### WARNING

**BEFORE CONNECTING THE POWER SENSOR TO ANOTHER INSTRUMENT, ensure that the instrument and power meter are connected to the protective (earth) ground.**

---

### Power Meter Calibrations

Power Meter to Power Sensor calibration procedures differ with the power meter. Follow the calibration procedure located in your power meter's user's guide.

**Temperature Sensitivity** The sensitivity of the power sensor is influenced by ambient temperature. The sensor should be recalibrated at each change in temperature to obtain the most accurate results. Typical temperature sensitivity variations are shown in Figure 1-7 for the 8481D power sensor.

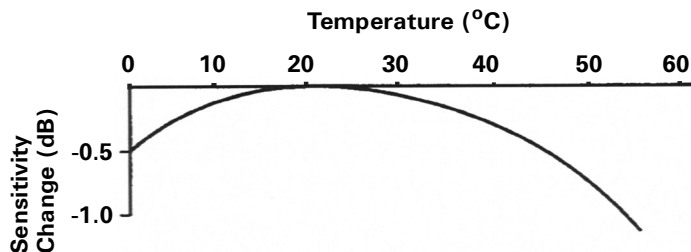
**Figure 1-7** Typical Influence of Temperature on Sensitivity

### Operating Instructions

To operate the Power Sensor, refer to the operating instructions in of the power meter's user's guide.

### Power Measurements

To correct for varying responses at different frequencies a cal factor table is included on the Power Sensors. To use the cal factor at the frequency of interest, adjust the power meter's CAL FACTOR control according to the instructions in the power meter's user's guide.

### Modulation Effects

When measuring RF or microwave sources that are modulated at the chopper frequency (nominally 220 Hz), at the first or second harmonic or submultiples of the chopper frequency, beat notes may occur. Unless these beat notes are exactly the chopper frequency, they can usually be eliminated by averaging (filtering) since the amplitudes are plus and minus the actual power. These frequencies may also be avoided by changing the modulation frequency slightly, if possible.

Refer to the power meter's user's guide for information on setting the averaging (filtering).

Introduction  
**Operation**

---

## **2** **General Information**

This chapter contains information about recommended equipment, performance tests, and replacement parts of the Agilent Coaxial Power Sensors.

---

## Recommended Test Equipment

Table 2-1 lists the test equipment recommended to check, adjust, and troubleshoot the Power Sensor. If substitute equipment is used, it must meet or exceed the critical specifications to be used in place of the recommended instruments for servicing the Power Sensor.

---

**NOTE** Check the Power Sensor's warranty. Opening it voids the warranty.

---

**Table 2-1 Recommended Test Equipment (done)**

Instrument Type	Critical Specifications	Suggested Model	Use <sup>a</sup>
Power meter	No Substitute	E4418B (Modified - See Appendix A)	A
Digital Voltmeter	<ul style="list-style-type: none"><li>• Range: 100 mVdc to 100 Vdc</li><li>• Input Impedance: 100 mohm;</li><li>• Resolution: 4-digit</li><li>• Accuracy: <math>\pm 0.05\%</math> <math>\pm 1</math> digit</li></ul>	34401A	T
Oscilloscope	<ul style="list-style-type: none"><li>• Bandwidth: dc to 50 MHz</li><li>• Sensitivity: Vertical, 50 mV/div</li><li>• Horizontal, 500 <math>\mu</math>s/div</li></ul>	54622A	A,T
BNC(m) to BNC(m) (2 required)		10503C	A
Ohmmeter	<ul style="list-style-type: none"><li>• Range: 1 - 100,000 ohm;</li><li>• Accuracy: <math>\pm 5\%</math></li></ul>	34401A	T

a. A = Adjustment, T = Troubleshooting



---

## Connector Care

Keeping in mind its flammable nature, a solution of pure isopropyl or ethyl alcohol can be used to clean connectors.

---

### CAUTION

The RF connector bead deteriorates when contacted by any chlorinated or aromatic hydrocarbon such as acetone, trichlorethane, carbon tetrachloride, and benzene.

Do not attempt to clean connectors with anything metallic such as pins or paper clips.

---

Clean the connector face by first using a blast of compressed air. If the compressed air fails to remove contaminants use a cotton swab dipped in isopropyl or ethyl alcohol. If the swab is too big, use a round wooden toothpick wrapped in a lint free cloth dipped in isopropyl or ethyl alcohol.

## Torque

For operation to 18 GHz, the newer 8480 series power sensors have a Type-N hex nut for tightening to the device-under-test or the power meter's 1 mW Power Reference. Older 8480 series power sensors have a knurled portion on the connector. Turn the connector nut (or knurled portion) only to tighten, the torque should not exceed 135 N-cm (12 in-lb) to avoid damage to the connector.

For APC3.5 mm and 2.4mm connectors the torque should not exceed 90 N-cm (8 in-lb) to avoid damage to the connector.

---

### CAUTION

Damage can occur if torque is applied to the power sensor body.

---

## Performance Test

### Standing Wave Ratio (SWR) and Reflection Coefficient (Rho) Performance Test

This section does not provide a preset test procedure since there are several test methods and different equipment available to make these measurements. Therefore, when measuring this specification, the actual accuracy of the test equipment must be taken into account in order to determine the pass/fail condition. The Maximum SWR values (also expressed in terms of the Reflection Coefficient [Rho]) for each model of Power Sensor are listed in Table 2-2.

**Table 2-2 Power Sensor SWR and Reflection Coefficient**

Frequency	Maximum SWR (Reflection Coefficient)	System SWR Uncertainty	Performance Limit (Rho - System Rho Uncertainty)	Actual Measurement
<b>8481A</b>				
10 to 30 MHz	< 1.40 (0.166)			
30 to 50 MHz	< 1.18 (0.083)			
50 MHz to 2 GHz	< 1.10 (0.048)			
2 to 12.4 GHz	< 1.18 (0.083)			
12.4 to 18 GHz	< 1.28 (0.123)			
<b>8482A</b>				
100 kHz to 300 kHz	< 1.60 (0.231)			
300 kHz to 1 MHz	< 1.20 (0.091)			
1 MHz to 2 GHz	< 1.10 (0.048)			
2 to 4.2 GHz	< 1.30 (0.130)			

**Table 2-2 Power Sensor SWR and Reflection Coefficient**

<b>Frequency</b>	<b>Maximum SWR (Reflection Coefficient)</b>	<b>System SWR Uncertainty</b>	<b>Performance Limit (Rho - System Rho Uncertainty)</b>	<b>Actual Measurement</b>
<b>8483A</b>				
100 kHz to 600 kHz	< 1.80 (0.286)			
600 kHz to 2 GHz	< 1.18 (0.083)			
<b>8485A</b>				
50 to 100 MHz	< 1.15 (0.070)			
0.1 to 2 GHz	< 1.10 (0.048)			
2 to 12.4 GHz	< 1.15 (0.070)			
12.4 to 18 GHz	< 1.20 (0.091)			
18 to 26.5 GHz	< 1.25 (0.111)			
26.5 to 33 GHz	< 1.40 (0.166)			
<b>8487A</b>				
50 to 100 MHz	< 1.15 (0.070)			
0.1 to 2 GHz	< 1.10 (0.048)			
2 to 12.4 GHz	< 1.15 (0.070)			
12.4 to 18 GHz	< 1.20 (0.091)			
18 to 26.5 GHz	< 1.25 (0.111)			
26.5 to 40 GHz	< 1.30 (0.130)			
40 to 50 GHz	< 1.50 (0.20)			

**Table 2-2 Power Sensor SWR and Reflection Coefficient**

Frequency	Maximum SWR (Reflection Coefficient)	System SWR Uncertainty	Performance Limit (Rho - System Rho Uncertainty)	Actual Measurement
<b>8481B</b>				
10 MHz to 2 GHz	< 1.10 (0.048)			
2 to 12.4 GHz	< 1.18 (0.083)			
12.4 to 18 GHz	< 1.28 (0.123)			
<b>8482B</b>				
100 kHz to 2 GHz	< 1.10 (0.048)			
2 to 4.2 GHz	< 1.18 (0.083)			
<b>8481H</b>				
10 MHz to 8 GHz	< 1.20 (0.091)			
8 to 12.4 GHz	< 1.25 (0.112)			
12.4 to 18 GHz	< 1.30 (0.130)			
<b>8482H</b>				
100 kHz to 4.2 GHz	< 1.20 (0.091)			
<b>8481D</b>				
10 to 30 MHz	< 1.40 (0.167)			
0.03 to 4 GHz	< 1.15 (0.070)			
4 to 10 GHz	< 1.20 (0.091)			
10 to 15 GHz	< 1.30 (0.130)			
15 to 18 GHz	< 1.35 (0.112)			

**Table 2-2 Power Sensor SWR and Reflection Coefficient**

<b>Frequency</b>	<b>Maximum SWR (Reflection Coefficient)</b>	<b>System SWR Uncertainty</b>	<b>Performance Limit (Rho - System Rho Uncertainty)</b>	<b>Actual Measurement</b>
<b>8485D</b>				
50 to 100 MHz	< 1.19 (0.085)			
0.1 to 4 GHz	< 1.15 (0.070)			
4 to 12 GHz	< 1.19 (0.085)			
12 to 18 GHz	< 1.25 (0.112)			
18 to 26.5 GHz	< 1.29 (0.127)			
<b>8487D</b>				
50 to 100 MHz	< 1.19 (0.085)			
0.1 to 2 GHz	< 1.15 (0.069)			
2 to 12.4 GHz	< 1.20 (0.091)			
12.4 to 18 GHz	< 1.29 (0.127)			
18 to 34 GHz	< 1.37 (0.156)			
34 to 40 GHz	< 1.61 (0.234)			
40 to 45 GHz	< 1.86 (0.301)			
45 to 50 GHz	< 1.89 (0.310)			

## Replaceable Parts

Table 2-3 to Table 2-8 are a list of replaceable parts. Figure 2-1 illustrates the major parts. To order a part listed in Table 2-3 to Table 2-8, contact your nearest Agilent Technologies Sales and Service Office.

**Figure 2-1** Illustrated Major Parts Breakdown

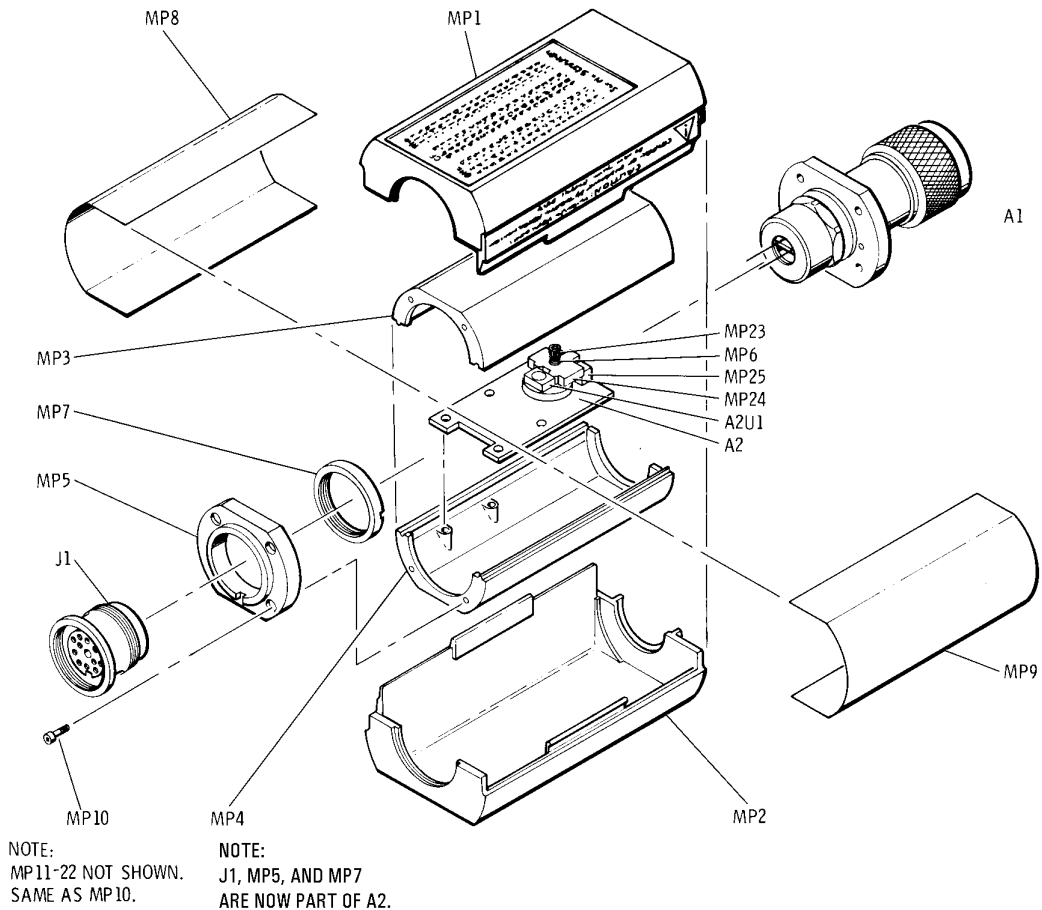

**Table 2-3 Bulkhead Assembly**

<b>Model</b>	<b>Reference Designator</b>	<b>Part Number</b>	<b>Qty</b>	<b>Description</b>
8481A	A1	08481-60004	1	Bulkhead Assembly, Type N
8481A Opt 001	A1	08481-60005	1	Bulkhead Assembly, Type APC-7
8482A	A1	08482-60003	1	Bulkhead Assembly, Type N
8483A	A1	08483-60003	1	Bulkhead Assembly, Type N
8485A	A1	08485-60007	1	Bulkhead Assembly, 3.5mm
8485A Opt 033	A1	08485-60011	1	Bulkhead Assembly, 3.5mm
8487A	A1	08487-60002	1	Bulkhead Assembly, 2.4mm
8481B	A1	08481-60019	1	Bulkhead Assembly, Type N
8482B	A1	08482-60011	1	Bulkhead Assembly, Type N
8481D	A1	08481-60145	1	Bulkhead Assembly, Type N
8485D	A1	08485-60008	1	Bulkhead Assembly, 3.5mm
8485D Opt 033	A1	08485-60012	1	Bulkhead Assembly, 3.5mm
8487D	A1	08487-67002	1	Bulkhead Assembly, 2.4mm
8481H	A1	08481-60014	1	20dB Bulkhead Assembly, Type N
8482H	A1	08482-60009	1	20dB Bulkhead Assembly, Type N

General Information  
**Replaceable Parts**

**Table 2-4 Power Sensor Board Assemblies**

<b>Model</b>	<b>Reference Designator</b>	<b>Part Number</b>	<b>Qty</b>	<b>Description</b>
848xA	A2	5061-0982	1	Power Sensor Board Assembly
8481B/8482B	A2	08481-60039	1	Power Sensor Board Assembly
8481D/8485D/8487D	A2	5061-0983	1	Power Sensor Board Assembly
8481H/8482H	A2	08481-60040	1	Power Sensor Board Assembly

**Table 2-5 Common Chassis Components**

<b>Reference Designator</b>	<b>Part Number</b>	<b>Qty</b>	<b>Description</b>
MP1-MP2	5040-6998	2	Plastic Shell
MP3-MP4	08481-20011	2	Chassis
MP6	1460-1978	1	Compression Spring
MP8-MP9	08481-00002	2	Shield
MP10-MP22	0515-0879	13	Screw
MP23	3030-0436	1	Screw
MP24	5040-6939	1	Clamp
MP25	5040-6940	1	Block



**Table 2-6                      Adapters and Attenuators**

<b>Model</b>	<b>Part Number</b>	<b>Qty</b>	<b>Description</b>
8483A	1250-0597	1	50 Ohm to 75 Ohm Coax Adapter
8485A/8485D	08485-60005	1	3.5mm to N(m) Coax Adapter
8487A/8487D	08487-60001	1	2.4mm to N(m) Coax Adapter
8481B	08498-60001	1	Coaxial Fixed 30dB Attenuator
8482B	08498-60010	1	Coaxial Fixed 30dB Attenuator
8481D/8485D/8487D	11708-60001	1	Precision 30dB Attenuator

**Table 2-7                      Identification Labels**

<b>Model</b>	<b>Part Number</b>	<b>Qty</b>	<b>Description</b>
8481A	08481-80002	1	8481A ID Label
8482A	08482-80002	1	8482A ID Label
8483A	08483-80001	1	8483A ID Label
8485A	08485-80002	1	8485A ID Label
8487A	08487-80001	1	8487A ID Label
8481B	08481-80004	1	8481B ID Label
8482B	08482-80003	1	8482B ID Label
8481D	08481-80011	1	8481D ID Label
8485D	08485-80003	1	8485D ID Label
8487D	08487-80004	1	8487D ID Label
8481H	08481-80003	1	8481H ID Label
8482H	08482-80001	1	8482H ID Label

General Information  
**Replaceable Parts**

**Table 2-8                      Miscellaneous Labels**

<b>Part Number</b>	<b>Qty</b>	<b>Description</b>
08481-80115	1	Cal Label (Blank) - For Zebra brand printers
08486-80006	1	Cal Label (Blank) - For impact printers
08481-80005	1	Mylar Overlay - For use with Cal Label 08486-80006
08486-80005	1	Side Label - Agilent Branding
7121-2422	1	Side Label - Caution (For all models except 8487A/8487D)
08487-80002	1	Side Label - Caution (For 8487A/8487D)
00346-80011	1	Information Label (For 8481D/8485D/8487D)

---

# **3 Service**

This Service chapter contains information about principles of operation, troubleshooting, and repair of the Agilent Coaxial Power Sensors.

## Principles of Operation

### Thermocouple Sensors

The A1 Bulkhead Assembly presents a 50 Ohm load (75 Ohm for model 8483A) to the RF source.

The RF signal is coupled through a dc blocking capacitor and absorbed by the thermocouples, generating a dc voltage proportional to the RF input power. The dc voltage is routed from the thermocouples to the input amplifier via gold wires reducing unwanted thermocouple effects. The gold wires, located in the black plastic block, pass through ferrite beads A2E1 and A2E2. The ferrite beads increase the self-inductance of the gold wires creating an RF choke. The result is to minimize RF feedthrough to the A2 Power Sensor Board Assembly.

The dc output from the bulkhead assembly is applied to the two field effect transistors (FETs) in A2U1. These transistors function as a sampling gate or chopper. The sampling rate is controlled by a 220 Hz square wave supplied by the power meter. The amplitude of the sampling gate output (at pin 3 of A2U1) is a 220 Hz square wave proportional to the power input. The sampled 220 Hz ac output is applied to the input amplifier A2Q1, which is the input stage for an operational amplifier

The Auto Zero Feedback circuit is coupled to the power sensor from the power meter. The dc voltage used to set the zero level is applied to the input of FET A2U1 by using A2R1 and A1TC1 as a voltage divider.

When the Power Sensor is used with a Power Meter, the resistance to ground from J1-K (Mount Resistor) allows the Power Meter to determine the sensor's dynamic range.

## Diode Sensors

The A1 Bulkhead Assembly presents a 50 Ohm load to the RF source.

A diode assembly in the bulkhead rectifies the applied RF to produce a dc voltage that varies with the square of the RF power across the 50 Ohm load. Thus the voltage varies with the RF power dissipated in the load.

This low level DC voltage is passed on gold wires through ferrite beads A2E1 and A2E2. The ferrite beads increase the self-inductance of the gold wires causing this portion of the wires to provide the properties of an RF choke. The result is to minimize RF feedthrough to the A2 Power Sensor Board Assembly.

The dc output from the bulkhead assembly is applied to the two field effect transistors (FETs) in A2U1. These transistors function as a sampling gate or chopper. The sampling rate is controlled by a 220 Hz square wave supplied by the power meter. The amplitude of the sampling gate output (at pin 3 of A2U1) is a 220 Hz square wave proportional to the power input. The sampled 220 Hz ac output is applied to the input amplifier A2Q1, which is the input stage for an operational amplifier.

The A2 Power Sensor Board Assembly also contains various components that comprise a shaping network. This network brings about a linear change in the amplitude of the square wave output as RF input power changes. A shaping network is necessary in diode power sensors to compensate for the characteristics of the thermocouple type shaping in the power meter, and to make minor diode corrections. In order to bring about a linear change in amplitude, the components in this network are factory selected to match variations of the diode assembly in the bulkhead.

The Auto Zero Feedback circuit is coupled to the power sensor from the power meter. The dc voltage used to set the zero level is applied to the input of FET A2U1 by using A2R1 and A1TC1 as a voltage divider.

When the Power Sensor is used with a Power Meter, the resistance to ground from J1-K (Mount Resistor) allows the Power Meter to determine the sensor's dynamic range.

Figure 3-1 Schematic Diagram

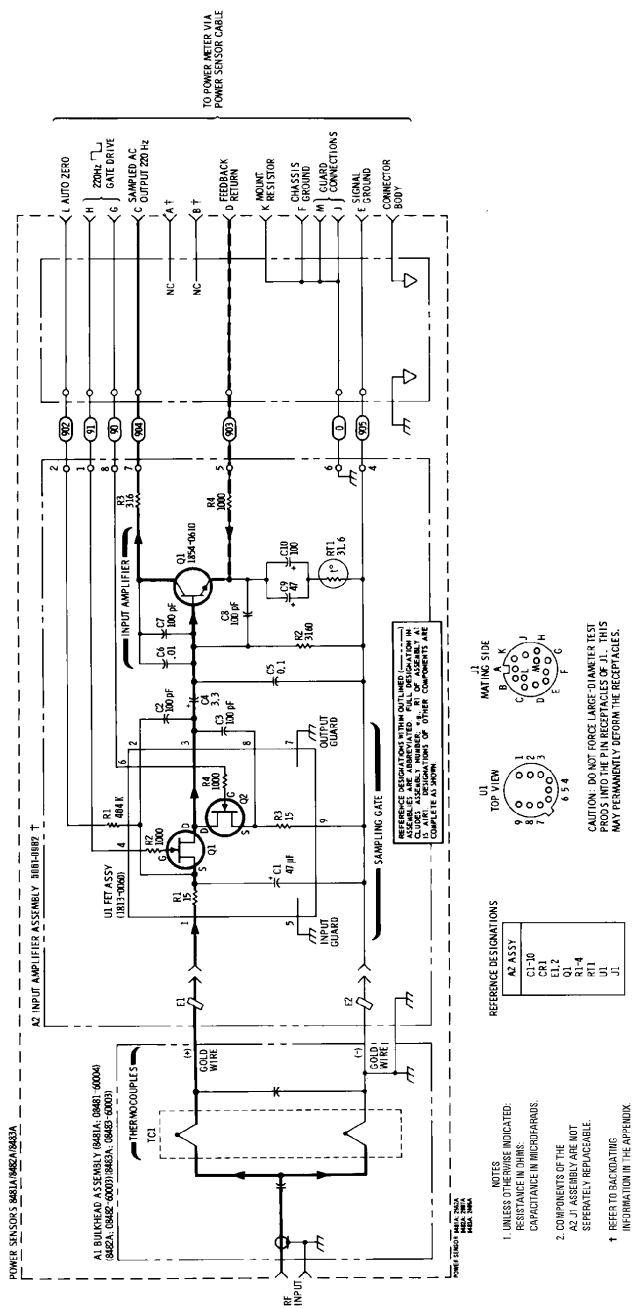

## Troubleshooting

Troubleshooting information is intended to first isolate the Power Sensor or the Power Meter as the defective component. When the Power Sensor is isolated, troubleshooting information is intended to identify the A1 Bulkhead Assembly or the A2 Power Sensor Board Assembly as the defective component.

Before you open the Power Sensor to continue with the troubleshooting procedures, try the substitution method of elimination. Use another power meter, known to be in good operating condition, with the suspected power sensor and cable. If the same problem occurs with the “known good” power meter, substitute a “known good” power sensor cable.

Troubleshooting should be performed with the Power Sensor opened, and the printed circuit board exposed. Refer to the “Disassembly / Reassembly Procedures” on page 49.

When a failed assembly has been identified, refer to the repair section in either the “A1 Bulkhead Assembly” on page 43 or the “A2 Power Sensor Board Assembly” on page 44.

---

**NOTE**

The FETs in A2U1 are light sensitive, and dc levels are shifted slightly when the FETs are exposed.

---

---

**CAUTION**

Excessive power damages the Power Sensor.

---

---

**CAUTION**

Electrostatic discharge renders the Power Sensor inoperative. Troubleshooting and Repair procedures must be carried out at a static free workstation.

---

## Troubleshooting - Eliminating the Power Meter and Sensor Cable

Where a “known good” power meter and/or sensor cable is unavailable, another means must be used to isolate the fault to the Power Sensor.

This is done by ensuring the power meter is providing the correct 220Hz drive signal. Check the following levels of the square wave with an oscilloscope.

- At the black/white wire:  $-0.05 \pm 0.05$  Vdc (top of square wave).
- At the brown/white wire: -9Vdc (bottom of square wave).

If the levels are incorrect, then the power meter or sensor cable is at fault. Refer to the power meter service manual for troubleshooting information.

If the levels are correct then the Power Sensor is at fault. Continue by troubleshooting the A1 Bulkhead Assembly.

## Troubleshooting - Power Sensors

The most common cause of Power Sensor failure is the application of power levels beyond the specified tolerance. The second most common cause of failure is applying torque to the body of the Power Sensor. Either of these common causes damages the bulkhead cartridge unit (which holds the thermocouples/diodes). If this happens, the fault causes a short or an open between the two gold wires.

### A1 Bulkhead (Thermocouple Sensors)

---

**CAUTION**

Disconnect the gold wires from the A2 assembly before measuring the resistance. Be extremely careful when measuring across the gold wires. They are delicate and can be damaged easily.

---

- Step 1.** Disconnect all cables from the Power Sensor.
- Step 2.** Remove the clamp holding the two gold wires.
- Step 3.** Resistance measured between the two gold wires from the A1 Bulkhead Assembly is listed in Table 3-1.



**Table 3-1 Bulkhead Assembly Resistance**

<b>Model</b>	<b>Measured Resistance</b>
8481A, 8481B, 8481H, 8485A, 8487A:	200 Ohms ± 10 Ohms
8482A, 8482B, 8482H:	245 Ohms ± 12.5 Ohms
8483A:	375 Ohms ± 17.5 Ohms

If the resistance value is incorrect (failure is usually indicated by an open circuit), then the A1 Bulkhead Assembly is defective. If the resistance is correct then continue to test the A2 Power Sensor Board Assembly.

**A1 Bulkhead (Diode Sensors)**

---

**CAUTION**

Disconnect the gold wires from the A2 assembly before measuring the voltage. Be extremely careful when measuring across the gold wires. They are delicate and can be damaged easily.

---

- Step 1.** Disconnect all cables from the Power Sensor.
- Step 2.** Remove the clamp holding the two gold wires.
- Step 3.** Connect the Precision 30dB Attenuator to the 1mW Power Reference connector on the power meter.
- Step 4.** Connect the Power Sensor to the Precision 30dB Attenuator.

---

**NOTE**

Models 8485A and 8487A require 3.5mm and 2.4mm adapters respectively.

---

- Step 5.** Turn on the 1mW Power Reference, and measure the voltage across the two gold wires. The voltage should be between 0.9mV and 1.5mV. If the voltage is incorrect, then the A1 Bulkhead Assembly is defective. If the voltage is correct then continue to test the A2 Power Sensor Board Assembly.

### **A2 Power Sensor Board Assembly**

It is extremely rare for the A2 Assembly to fail. Eliminate the power meter, the sensor cable, and the A1 Bulkhead Assembly before suspecting the A2 Assembly.

In most cases, the operational amplifier (made up of A2Q1 and the first amplifier of the power meter,) is operating correctly if the dc voltage on the metal cover of A2Q1 (collector) is  $-70 \pm 30$  mV dc.

## Repair

Power Sensor repair consists of replacing either the A1 Bulkhead Assembly, or the A2 Power Sensor Board Assembly.

### A1 Bulkhead Assembly

#### Repair Strategy

The recommended repair strategy for the A1 Bulkhead Assembly is to completely replace it. The replacement Bulkhead is calibrated at the factory, and is supplied with a calibration report and a new calibration sticker for the Power Sensor.

#### Procedure

- Step 1.** Order your new or restored A1 Bulkhead Assembly from Table 2-3, “Bulkhead Assembly,” on page 31.
- Step 2.** Follow the disassembly and reassembly procedures for Bulkhead removal and replacement. See “Disassembly / Reassembly Procedures” on page 49.
- Step 3.** Check the FET balance using the procedure described in “FET Balance Adjustment” on page 45. If you did not disturb the wires, it is likely that no adjustment is necessary.
- Step 4.** Place the new calibration sticker on the plastic shell of the Power Sensor.

---

#### NOTE

Although the recommended Bulkhead strategy is to completely replace it, we are aware that some customers have both the ability and experience that enables them to disassemble and repair Bulkheads to a lower level. For this reason, Appendix B provides exploded views of the various Bulkheads, and tables listing the parts.

Lower level Bulkhead repair can be more economical than replacement, although this may be offset by the need to invest in sensor calibration equipment and a SWR test set-up.

---

## **A2 Power Sensor Board Assembly**

### **Repair Strategy**

The recommended repair strategy for the A2 Power Sensor Board Assembly is to completely replace it. Replacing this assembly is usually less costly than the time it takes to troubleshoot and replace faulty components.

### **Procedure**

When replacing the A2 Power Sensor Board Assembly, some soldering is required in order to remove and replace the wires from connector J1. Remember that the Power Sensor is a highly sensitive device. As such, it is affected by very small temperature differences between its components. After performing any soldering in the unit, wait several hours for the unit to reach thermal equilibrium before using or testing it.

1. Use a temperature controlled 600F (311C) with a zero crossover tip.
2. Use a low temperature RMA flux SN 62 solder.
3. Do not attempt to remove flux residue from around solder joints. Using a cleaning solution may spread the flux over the entire assembly in a thin sticky layer.

## FET Balance Adjustment

The FET balance adjustment should be performed if the wires connecting J1 (the sensor cable connector) to A2 (the power sensor board assembly) have been moved. If you have replaced A2 assembly or moved the wires during troubleshooting you need to perform this adjustment.

---

### NOTE

You do not need to perform a FET balance adjustment after an A1 bulkhead assembly replacement, if the wires between J1 and A2 have not been disturbed.

---

### Equipment Required

- Oscilloscope
- BNC cables (2 required)
- Power Meter (Modified as described in Appendix A)

### Test Description

This test applies to both thermocouple and diode power sensors. Among the required equipment is a modified E4418B Power Meter. The High Gain output of the power meter is connected to Channel 1 of an oscilloscope, and the Chop Output (220Hz square wave) of the power meter is connected to the oscilloscope trigger - the High Gain output is the amplified version of the Power Sensor chopped signal. Ideally, when no RF power is applied to the power sensor, the High Gain output signal displayed on the oscilloscope is a straight line. If there is a sensor offset, the offset signal is visible on the oscilloscope as a square wave (chopped signal). Also, a switching transient (spike) usually occurs at the edge of the chopped signal, due to the switching of the FET in the Power Sensor. Sensor offset and spike balance are affected by the relative positions of the wires connected to pins G and H of connector J1. One wire is black and white; the other is brown and white. Moving the black and white wire adjusts the amplitude of the switching transient (spike). Moving the brown and white wire changes the offset. Once positioned, care must be taken not to displace these wires. To correctly position these wires, perform the “FET Balance Procedure” on page 46.

Service  
FET Balance Adjustment

### FET Balance Procedure

**Step 1.** Set the Power Meter as follows:

CAL FACTOR	100%
POWER REF	ON

**Step 2.** Connect the **HIGH GAIN OUTPUT** on the modified Power Meter to **CHANNEL 1** on the Oscilloscope and set it up as follows:

POSITION	0 Volts (centered)
COUPLING	AC
PROBE	1:1
DISPLAY	AVERAGE
AVERAGE	8
VECTORS	ON
GRID	ON
MAIN/DELAYED	MAIN
TIME REF	CENTER
TIME/DIV	500us
VOLTS/DIV	50 mV

**Step 3.** Connect the **CHOP OUTPUT** on the modified Power Meter to **CHANNEL 2** on the Oscilloscope and set it up as follows:

MODE	AUTO LEVEL
TRIGGER SOURCE	CHANNEL 2
VOLTS/DIV	5V
POSITION	-5V

**Step 4.** Connect the Power Sensor to channel A of the Power Meter.

---

**NOTE** Heat can affect the adjustments so handle the sensor as little as possible.

---

**Step 5.** Adjust the black/white and brown/white wires until the waveform shown on the oscilloscope is similar to that shown in Figure 3-2. This shows an example of a High Gain output signal with acceptable sensor offset and spike balance settings.

**Figure 3-2** Example of an Acceptable Waveform

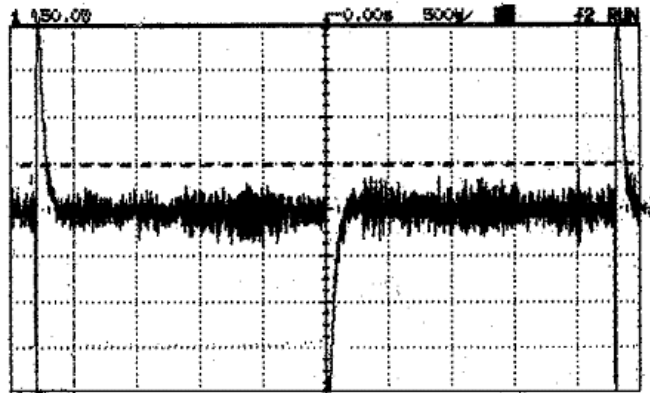

**Step 6.** Allow no more than 50mV variance on the sensor offset step (i.e. from top-to-top or bottom-to-bottom of the waveform). Figure 3-3 shows an example of a High Gain output signal with an unacceptably high sensor offset setting.

**Figure 3-3** Example of an Unacceptable Waveform

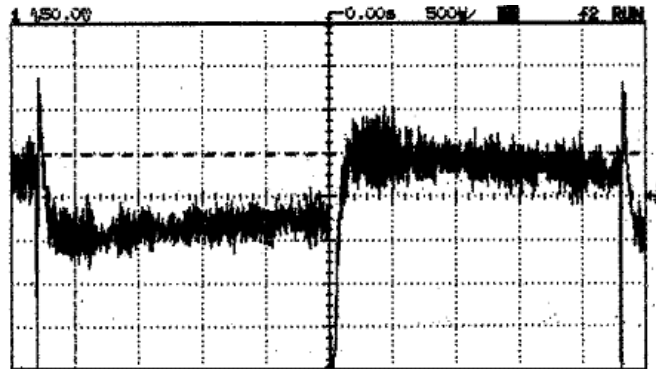

---

**TIP**

You will find that positioning the wire for switching transients affects the offset. Go back and forth between the two wires, positioning and repositioning, until both adjustments are deemed acceptable.

---

- Step 7.** Reassemble the Power Sensor, ensuring that the waveform shown on the oscilloscope does not change. If the waveform has changed, remove the cover and readjust the black/white and brown/white wires again.



## Disassembly / Reassembly Procedures

### Disassembly Procedure

Disassemble the Power Sensor by performing the following steps:

---

#### CAUTION

Disassembly must be performed in sequence described in the following procedure, otherwise damage may be caused to the two gold wires between the bulkhead assembly and the Power Sensor Board Assembly. If these wires are damaged, the A1 Bulkhead Assembly must be replaced.

---

---

#### NOTE

Every Power Sensor has an individually prepared label on the housing. If more than one power sensor is disassembled at a time, be sure to mate the correct Power Sensor and housing when reassembling.

---

- Step 1.** Insert the blade of a large screwdriver between the two-piece plastic shell at the rear of the Power Sensor. Gently pry the sections apart. (See Figure 3-4.)

**Figure 3-4**      **Removing the Power Sensor's Cover**

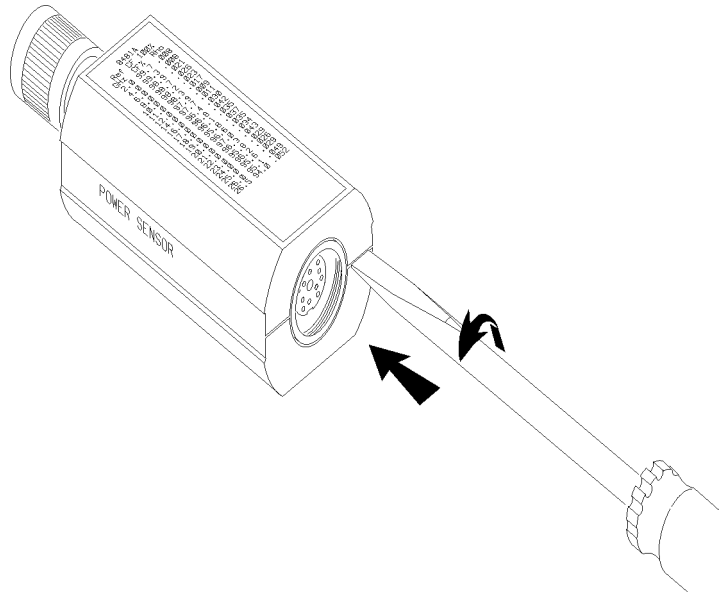

- Step 2.** At the other side of the sensor, again pry the cover shell sections apart. Remove the shells and the inner magnetic shields.
- Step 3.** Position the Power Sensor as shown in Figure 3-5 (top). The small hole **5** should be on the left side of the RF input connector. Remove the allen cap screws **1, 2, 10, and 13**. Loosen **11 and 12**. Remove the upper chassis from the Power Sensor.
- Step 4.** Remove the spring clamp cap screw **7** to free the gold leads which come from the Bulkhead Assembly.
- Step 5.** Remove cap screws **3, 4, and 5**.
- Step 6.** Slide the Bulkhead Assembly straight out from the chassis.
- Step 7.** Remove cap screws **8, 9, 11, 12, 14, and 15**.
- Step 8.** Lift the A2 Input Amplifier and J1 connector out of the chassis.

**Figure 3-5**      **Power Sensor Hardware Locations**

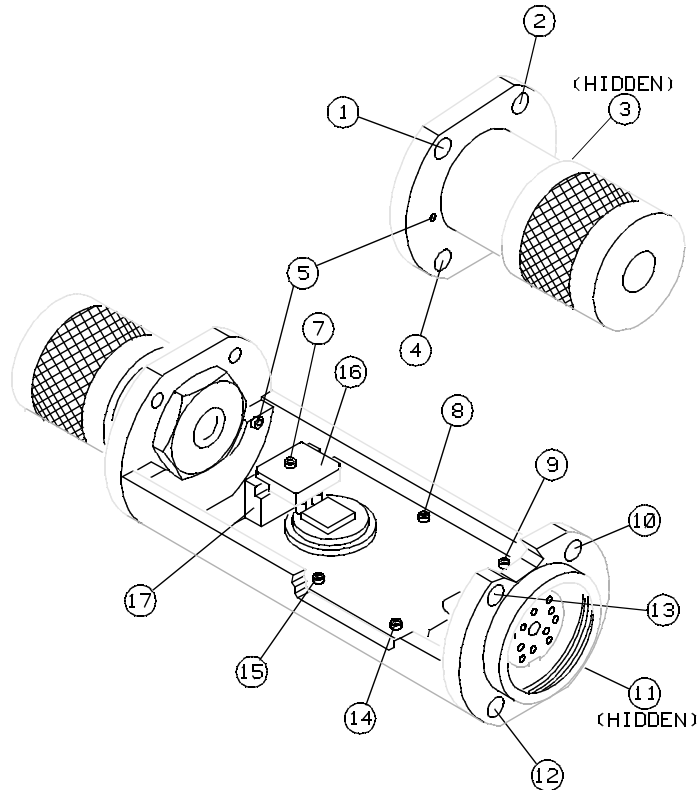

## Reassembly Procedures

---

### CAUTION

The gold wires connecting the A1 Bulkhead Assembly and the A2 Power Sensor Board Assembly are extremely delicate and may be easily broken. Be careful when working around them.

---

- Step 1.** Set the printed circuit board and connector into place as shown in Figure 3-5, bottom view.

Service  
Disassembly / Reassembly Procedures

- Step 2.** Insert cap screws **8, 9, 11, 12, 14,** and **15** but do not tighten.
- Step 3.** Center the circuit board so there is equal air gap between each side and the chassis. Tighten **8, 9, 14,** and **15.**
- Step 4.** Insert screw **3, 4,** and **5.** Tighten only screw **5.**
- Step 5.** With small hole **5** to the left, carefully insert the gold leads on A1 bulkhead assembly through the holes in the black plastic guide on A2 input amplifier.
- Step 6.** Using tweezers, position the ends of the gold wires over the electrical pads.

---

**CAUTION**

---

DO NOT tighten clamp screw **6** excessively or the FET circuit may be broken.

- Step 7.** Place and hold plastic clamp 16 over the gold wires. As you tighten the clamp screw, watch the compression spring. Tighten the clamp screw **7** only until the spring coils touch. Any further tightening could damage the FET circuit.
- Step 8.** Place the upper chassis in position and insert cap screws **1, 2, 10,** and **13.**
- Step 9.** Tighten **1, 2, 3,** and **4.**
- Step 10.** Tighten **10, 11, 12,** and **13.**
- Step 11.** Place the plastic shells, magnetic shields, and the chassis together as shown in Figure 2-1. Snap the plastic shells together.

---

# **A            EPM Series Power Meter (E4418B) Modification**

This Appendix describes the modification procedure for adapting an E4418B Power Meter to allow it to be used for the 8480 Series Power Sensor FET Balance Adjustment.

## The Material and Tools Required

---

### The Material and Tools Required

The following material and tools are required for this modification:

- A T-15 torque screwdriver.
- A Razor blade or Craft Knife.
- Three 30 cm lengths of AWG 20 single core wire.
- Three screw-fit BNC Female connectors (Agilent Part Number 1250-0118).
- A fine tip marker pen and adhesive labels.
- A 10-20 Watt pencil tip soldering iron.
- 60/40 0.8 mm rosin activated core solder wire.
- A Wire stripper.
- 25 lb/in Torque Wrench - Size 7/16 in. AF.

### Impact on Warranty

---

**NOTE**

Please be aware that doing this modification requires you to open the power sensor. Therefore, as stated earlier, any attempt to disassemble the power sensor will void the warranty.

---

---

## Modification Procedure

---

### CAUTION

Precautions must be taken to protect the Power Meter's PCBs from Electrical Static Damage (ESD).

---

- Step 1.** Using the T-15 torque screwdriver, remove the two screws shown in Figure A-1.

**Figure A-1**

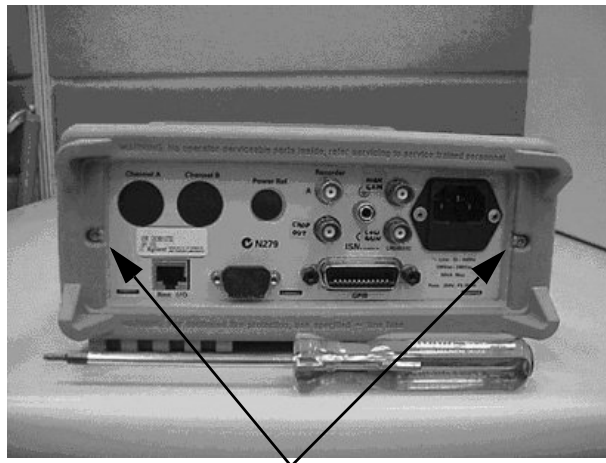

Remove these 2 screws

EPM Series Power Meter (E4418B) Modification  
Modification Procedure

**Step 2.** Remove the power meter handle. To remove the handle, pull the 2 ends as shown in Figure A-2.

**Figure A-2**



**Step 3.** Remove the power meter cover. To remove the cover, slide it open as shown in Figure A-3.

**Figure A-3**

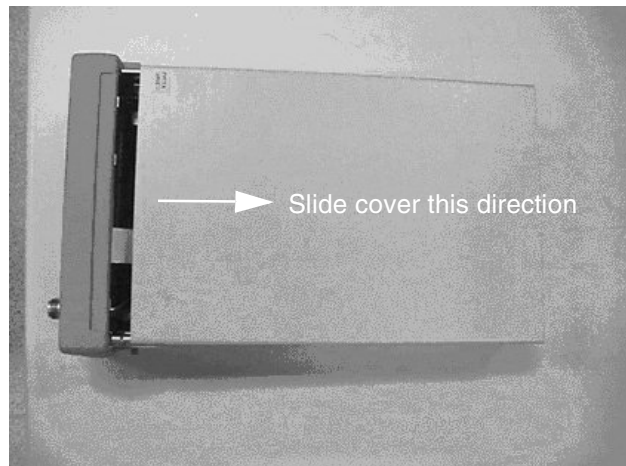



**Step 4.** Figure A-4 shows the power meter with its cover removed.

**Figure A-4**

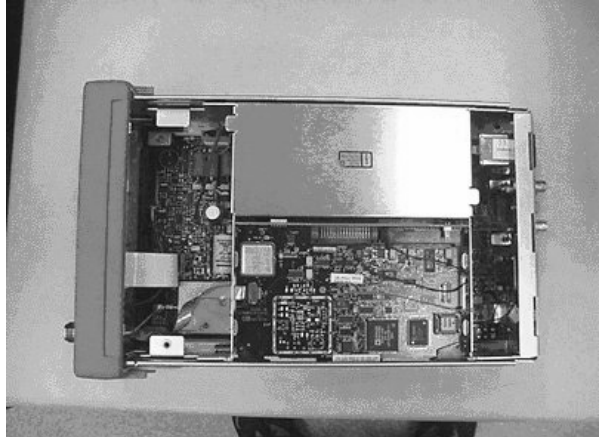

**Step 5.** Use the razor blade or craft knife to remove three hole plugs in the rear panel, as shown in Figure A-5.

**Figure A-5**

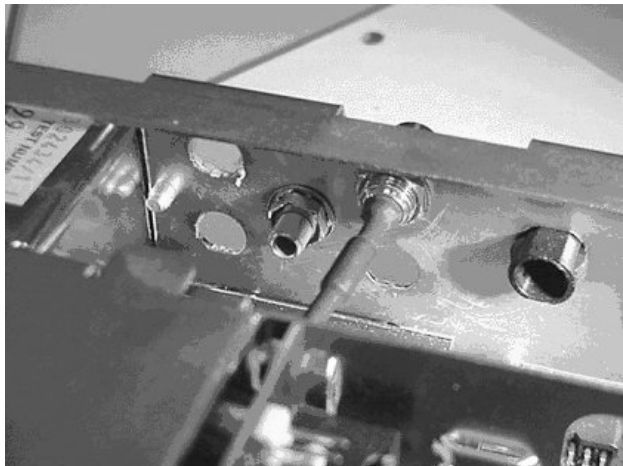

EPM Series Power Meter (E4418B) Modification  
Modification Procedure

**Step 6.** Figure A-6 shows a different view of the holes in the rear panel.

**Figure A-6**

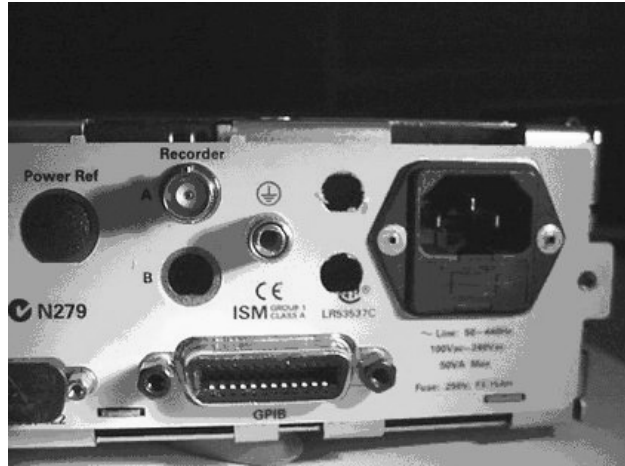

**Step 7.** Using the three lengths of AWG 20 wire, strip away 2cm from each end of the wires. Solder an end of each wire onto the screw-fit BNC female connectors, as shown in Figure A-7.

**Figure A-7**



**Step 8.** Securely fit the three BNC connectors into the three holes in the rear panel, as shown in Figure A-8. Use the 25 lb/in torque wrench to tighten the nuts.

**Figure A-8**

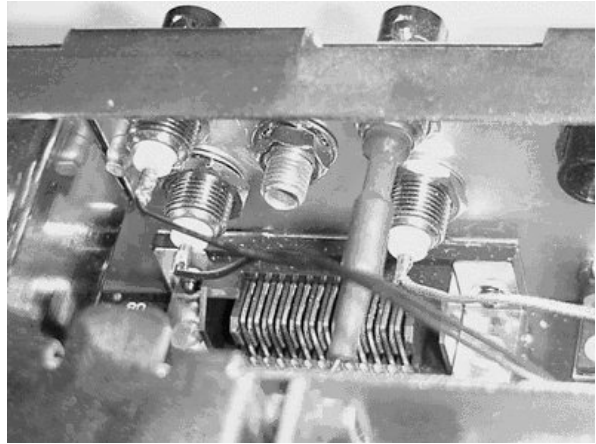

**Step 9.** The Measurement PCB (A6) must now be modified. The call outs in Figure A-9 show where the three wires need to be soldered. Solder a wire into each hole (Chop, Low Gain, and High Gain Outputs). Take care not to over heat the PCB, as this may damage the trace.

**Figure A-9**

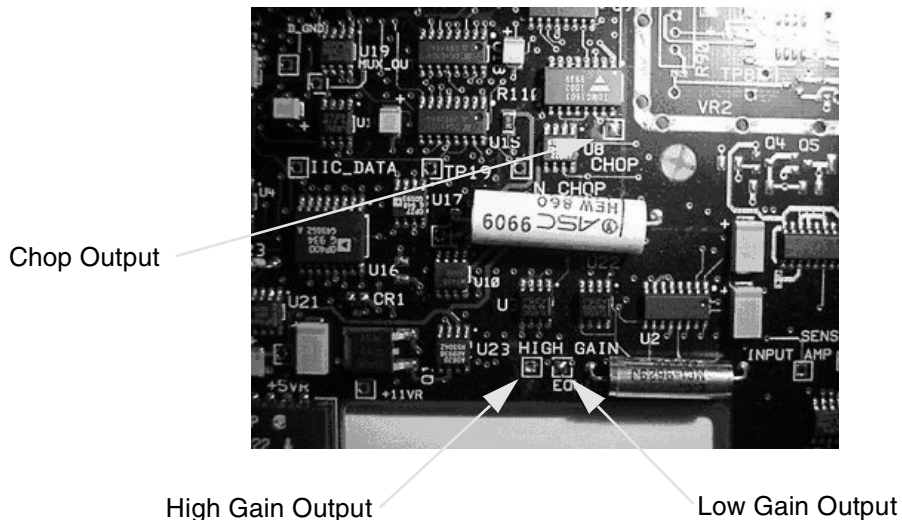

EPM Series Power Meter (E4418B) Modification  
Modification Procedure

**Step 10.** Figure A-10 shows a different view of the modified Measurement PCB.

**Figure A-10**

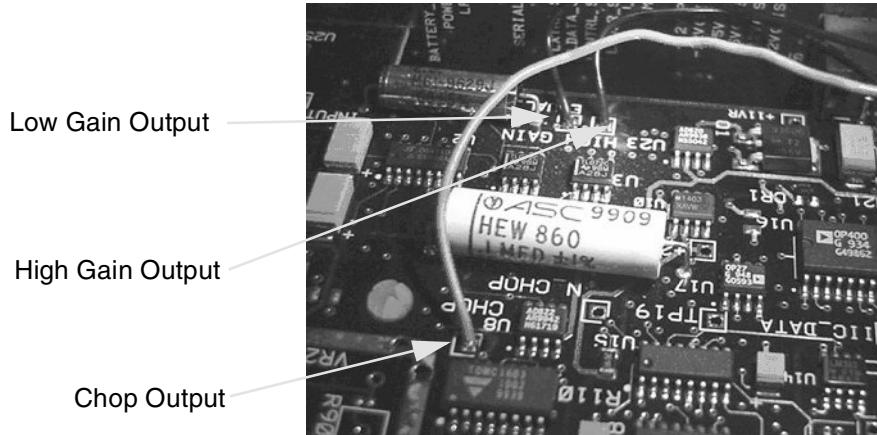

**Step 11.** Label each of the BNC connectors using the permanent marker and adhesive labels, as shown in Figure A-11. Refit the cover, handle, and the rear bumper to the power meter. Tighten both screws with the T-15 torque screwdriver.

**Figure A-11**



---

# **B Bulkhead Assemblies**

This Appendix contains the material lists and exploded graphics of the Bulkhead Assemblies.

Bulkhead Assemblies  
**Bulkhead Parts Lists**

## Bulkhead Parts Lists

**Table B-1 Bulkhead Parts for the 8481A, 8481B, 8482B, and 8482B Models**

Reference Designator	Part Description	Sensor Model		
		8481A 8481B	8481A Opt 001	8482A 8482B
MP1	Connector Nut	5021-7255	-	5021-7255
MP2	Connector Component	1250-0016	-	1250-0016
MP3	Connector Body	1250-2132	1250-1466	1250-2132
MP4	Contact Assembly	1250-0917	1250-0816	1250-0917
MP5	Insulator	5040-0306	5040-0306	5040-0306
MP6	Center Conductor - Cartridge Adapter	5020-3296	5020-3296	5020-3296
MP7	Compression Spring	1460-0977	1460-0977	1460-0977
MP8	Sliding Contact	5020-3297	5020-3297	5020-3297
MP9	Bulkhead	08481-20015	08481-20015	08481-20015
MP10	Flat Washer	2190-0831 or 3050-0622	2190-0831 or 3050-0622	-
MP11	Cap Nut	08481-20016	08481-20016	08481-20016
MP12	Polyiron	08481-40006	08481-40006	-
MP13	Protective Cap	1401-0099	1401-0099	1401-0099
MP14	Outer Conductor Spacer	5021-0830 or 08742-0006	5021-0830 or 08742-0006	5021-0830 or 08742-0006
MP15	Inner Conductor Spacer	5020-8540 or 08742-0005	5020-8540 or 08742-0005	5020-8540 or 08742-0005
A1	Cartridge	08481-60042	08481-60042	08482-60019

**Table B-2 Bulkhead Parts for the 8481D Model**

<b>Reference Designator</b>	<b>Part Description</b>	<b>Sensor Model</b>
		<b>8481D</b>
MP1	Connector Nut	5021-7255
MP2	Connector Component	1250-0016
MP3	Connector Body	1250-2132
MP4	Contact Assembly	1250-0917
MP5	Insulator	5040-0306
MP6	Center Conductor - Cartridge Adapter	5020-3296
MP7	Compression Spring	1460-0977
MP8	Sliding Contact	5020-3297
MP9	Adapter Connector	08481-20034
MP10	Center Conductor Contact	08481-20032
MP11	Insulator	5040-0306
MP12	Stepped Center Conductor	08481-20033
MP13	Rear Spacer	08481-20029
MP14	Bellows	0955-0238
MP15	Feed Thru Insulator	08486-40001
MP16	Rear Housing	08481-20028
MP17	Cap Nut	08486 20007
MP18	Compensation Washer	08481-20031
MP19	Outer Conductor Spacer	5021-0830
MP20	Inner Conductor Spacer	5020-8540
MP21	Inner Conductor Spacer	08742-0005
MP22	Outer Conductor Spacer	08742-0006
A1	Cartridge	08481-60041
H1	Flat Washer	2190-0831 or 3050-0622

Bulkhead Assemblies  
Bulkhead Parts Lists

**Table B-3 Bulkhead Parts for the 8481H and 8482H Models**

Reference Designator	Part Description	Sensor Model	
		8481H	8482H
MP1	Connector Nut	5021-7255	5021-7255
MP2	Connector Component	1250-0016	1250-0016
MP3	Connector Body	1250-2132	1250-2132
MP4	Contact Assembly	1250-0917	1250-0917
MP5	Insulator	5040-0306	5040-0306
MP6	Center Conductor - Cartridge Adapter	5020-3296	5020-3296
MP7	Compression Spring	1460-0977	1460-0977
MP8	Sliding Contact	5020-3297	5020-3297
MP9	Housing	08492-2000	08492-2000
MP10	Attenuator Adapter	5021 0154	5021 0154
MP11	Sliding Contact	5020-3297	5020-3297
MP12	Compression Spring	1460-1547	1460-1547
MP13	Contact Holder	5021-0157	5021-0157
MP14	Insulator	5040-0306	5040-0306
MP15	Center Conductor - Cartridge Adapter	5020-3296	5020-3296
MP16	Compression Spring	1460-0977	1460-0977
MP17	Sliding Contact	5020-3297	5020-3297
MP18	Bulkhead	08481-20015	08481-20015
MP19	Cap Nut	08481-20016	08481-20016
MP20	Protective Cap	1401-0099	1401-0099
MP21	Polyiron	08481-40006	-
MP22	Flat Washer	3050-0622	3050-0622
MP23	Flat Washer	3050-0622	3050-0622
MP24	Outer Conductor Spacer	5021-0830 or 08742-0006	5021-0830 or 08742-0006



**Table B-3                      Bulkhead Parts for the 8481H and 8482H Models**

Reference Designator	Part Description	Sensor Model	
		8481H	8482H
MP25	Inner Conductor Spacer	5020-8540 or 08742-0005	5020-8540 or 08742-0005
MP26	Flat Washer	2190-0831 or 3050-0622	-
A1	Cartridge	08481-60042	08482-60019
A2	Cartridge Assembly	08481-60011	08481-60011

Bulkhead Assemblies  
**Bulkhead Parts Lists**

**Table B-4                      Bulkhead Parts for the 8483A Model**

<b>Reference Designator</b>	<b>Part Description</b>	<b>Sensor Model</b>
		<b>8483A</b>
MP1	Connector Nut	5021-7255
MP2	Connector Component	1250-0016
MP3	Connector Body	1250-2132
MP4	Center Conductor, 75 Ohm	08483-20003
MP5	Insulator	5020-8593
MP6	Center Contact, 75 Ohm	08483-20002
MP7	Compression Spring	1460-0526
MP8	Sliding Contact	08491-2009
MP9	Bulkhead	08481-20015
MP10	Inner Conductor Spacer	00909-20006
MP11	Cap Nut	08481-20016
MP12	Information Label	7120-4351
MP13	Protective Cap	1401-0099
MP14	Outer Conductor Spacer	5021-0830 or 08742-0006
A1	Cartridge	08483-60010

**Table B-5 Bulkhead Parts for the 8485A and 8485D Models**

Reference Designator	Part Description	Sensor Model	
		8485A 8485A Opt 033	8485D 8485D Opt 033
MP1	Connector Nut	08485-20005	08485-20005
MP2	Connector Component	1250-0016	1250-0016
MP3	Bulkhead	08485-20011	08485-20011
MP4	Outer External Coax	5021-7092	5021-7092
MP5	Outer Conductor Spacer	00281-20046	00281-20046
MP6	Center Conductor	5040-6958	5040-6958
MP7	Center Internal Coax	5021-7093	5021-7093
MP8	Bellows	0955-0238	0955-0238
MP9	Outer Internal Coax	5021-7091	5021-7091
MP10	Bellows Spacer	5021-9206	5021-9206
MP11	Matching Washer	5021-7094 or 08485-20024	5021-7094 or 08485-20024
MP12	Feed Thru Insulator	08486-40001	08486-40001
MP13	Cap Nut	08486-20007	08486-20007
A1	Cartridge	08485-60015	08481-60041
C1	Fixed Capacitor, 1000Pf 50v	0160-4746	0160-4746

Bulkhead Assemblies  
Bulkhead Parts Lists

**Table B-6                      Bulkhead Parts for the 8487A and 8487D Models**

Reference Designator	Part Description	Sensor Model	
		8487A	8487D
MP1	Connector Nut	5021-7081	5021-7081
MP2	Connector Component	1250-0016	1250-0016
MP3	Bulkhead	08487-20001	08487-20001
MP4	Outer External Coax	08487-20002	08487-20002
MP5	Pin Depth Washer	08487-00001	08487-00001
MP6	Center Contact	1250-2115	1250-2115
MP7	Bead Ring Assembly	1250-2107	1250-2107
MP8	Internal Center Conductor	08487-20003	08487-20003
MP9	Bellows	0955-0333	0955-0333
MP10	Outer Internal Coax	08487-20004	08487-20004
MP11	Matching Washer	08487-20006, 08487-20005, or 08487-20007	08487-20006, 08487-20005, or 08487-20007
MP12	Matching Washer	08487-20011 or 5022-2866 or 5022-2878 or 5022-3611	08487-20011 or 5022-2866 or 5022-2878 or 5022-3611
MP13	Polyiron	-	08673-20046
MP14	Feed Thru Insulator	08486-40001	08486-40001
MP15	Cap Nut	08486-20007	08486-20007
A1	Cartridge	08487-67110	08487-60004
C1	Fixed Capacitor, 1700Pf 50v	0160-6978	0160-6978

---

## Bulkhead Exploded Graphics

**Figure B-1**      **8481A and 8481B**

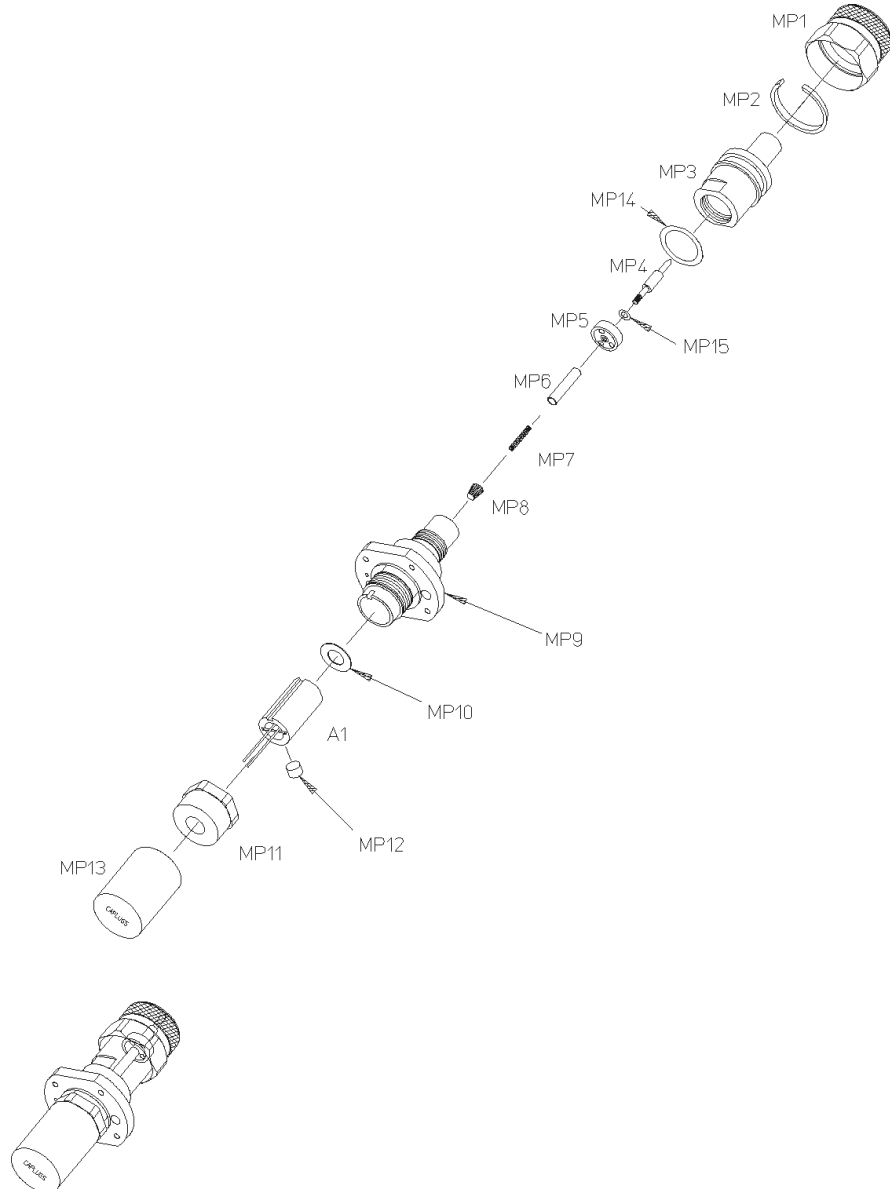

Bulkhead Assemblies  
Bulkhead Exploded Graphics

Figure B-2

8481A Option 001

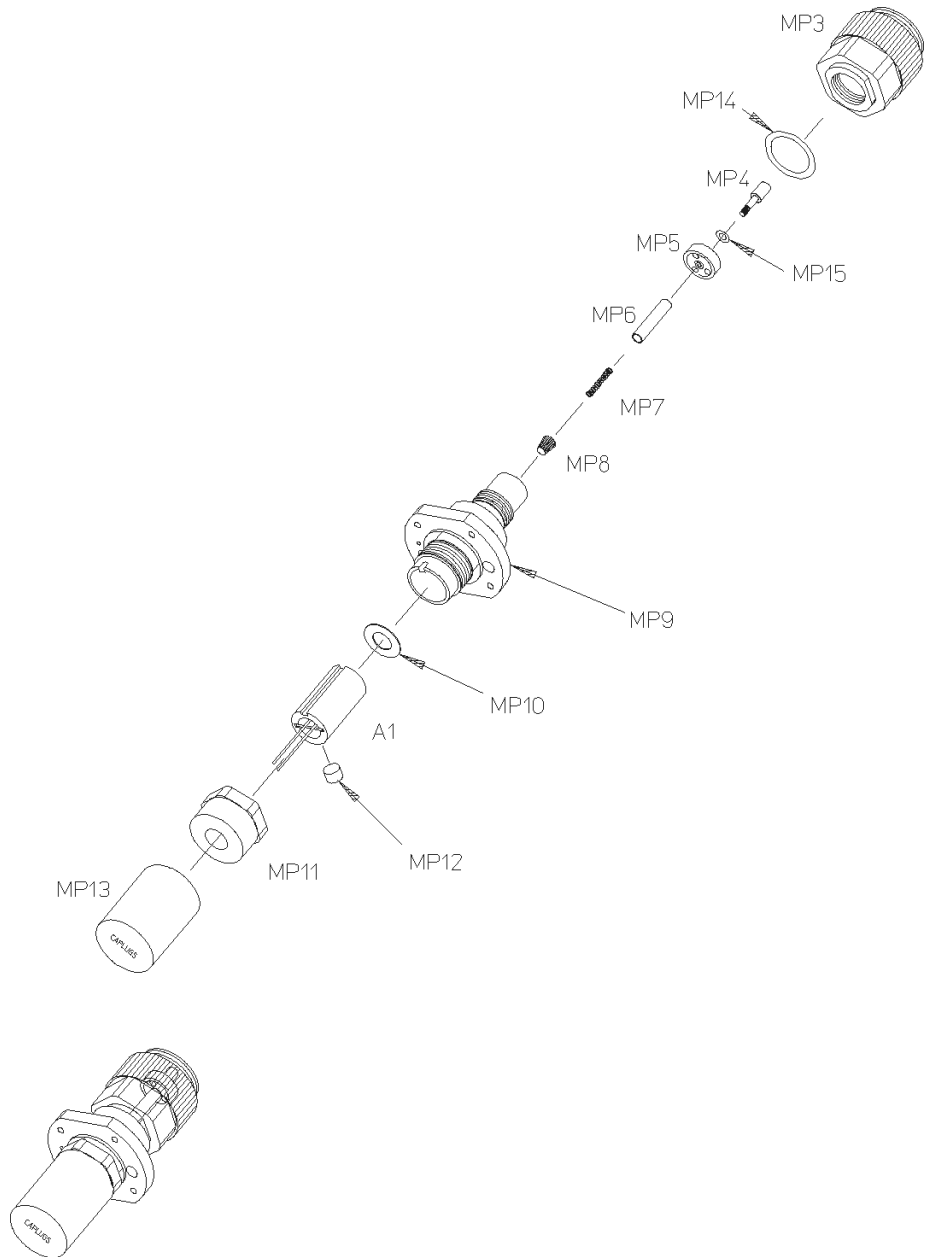
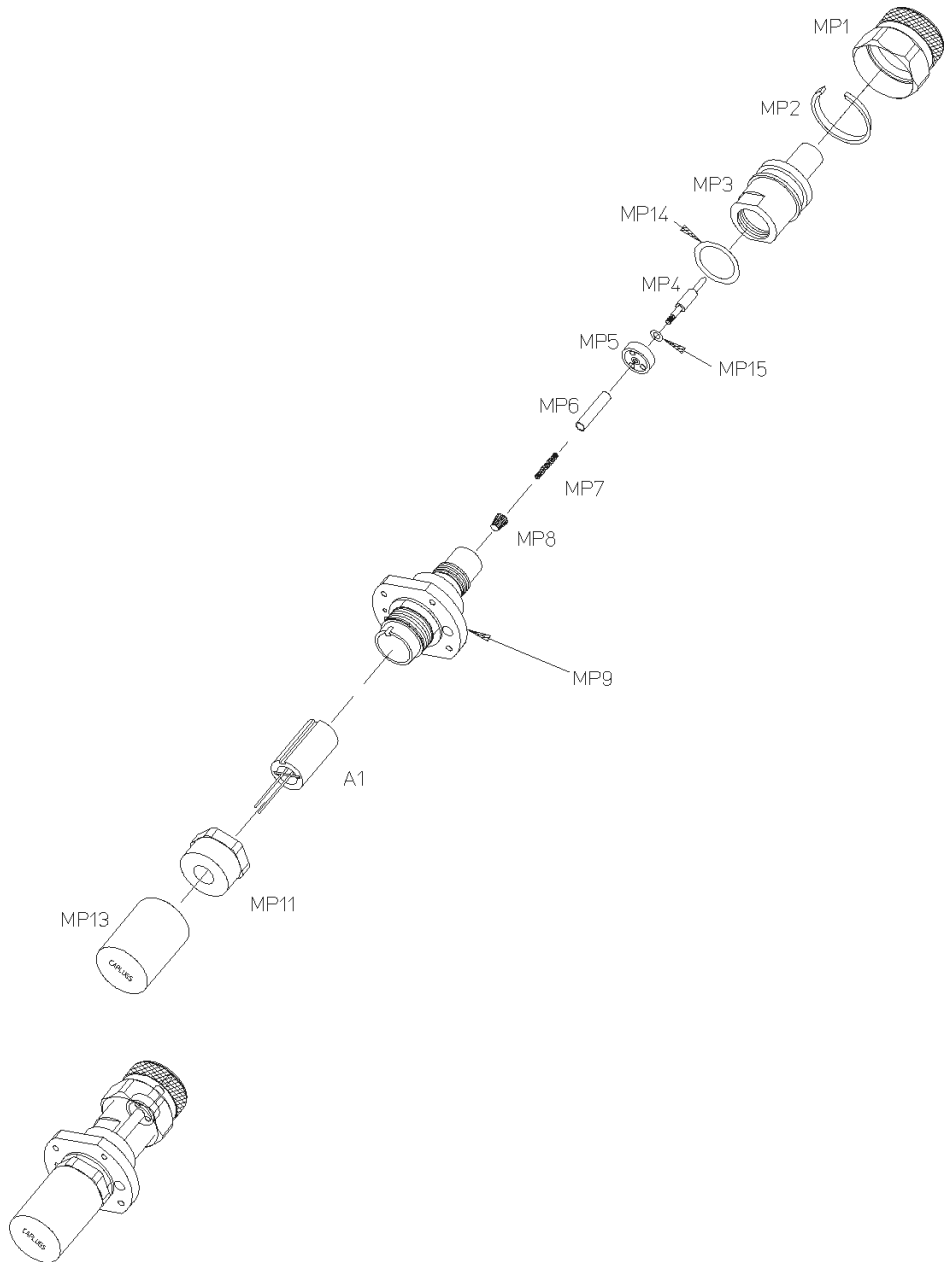

Figure B-3 8482A and 8482B



Bulkhead Assemblies  
Bulkhead Exploded Graphics

Figure B-4

8481D

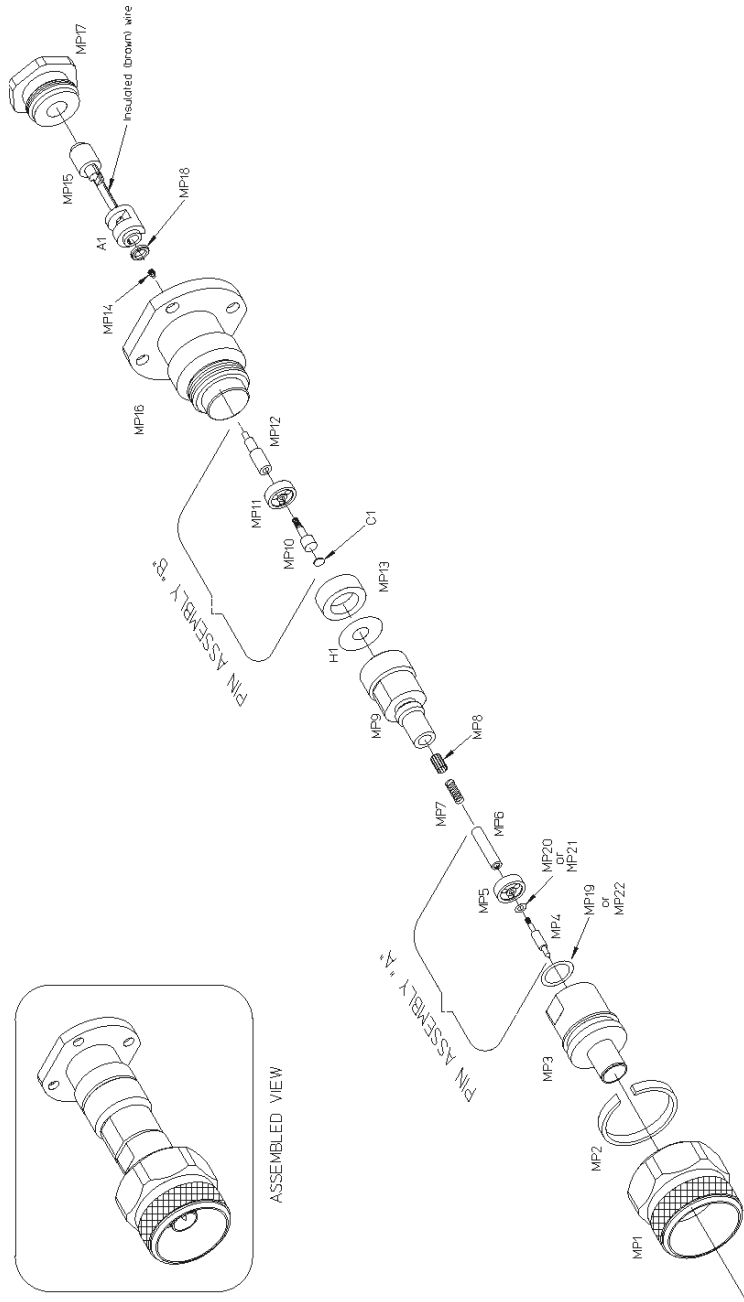
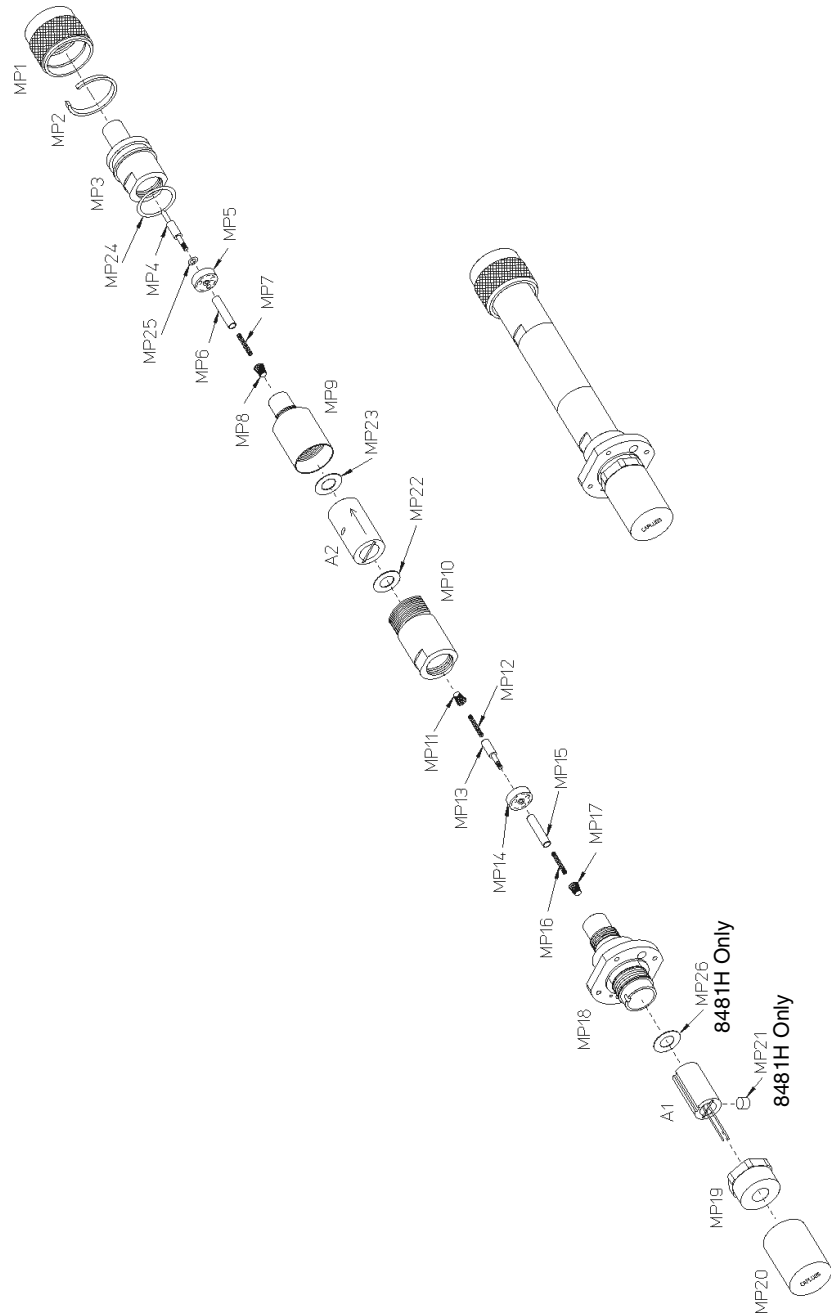



Figure B-5 8481H and 8482H



Bulkhead Assemblies  
Bulkhead Exploded Graphics

Figure B-6

8483A

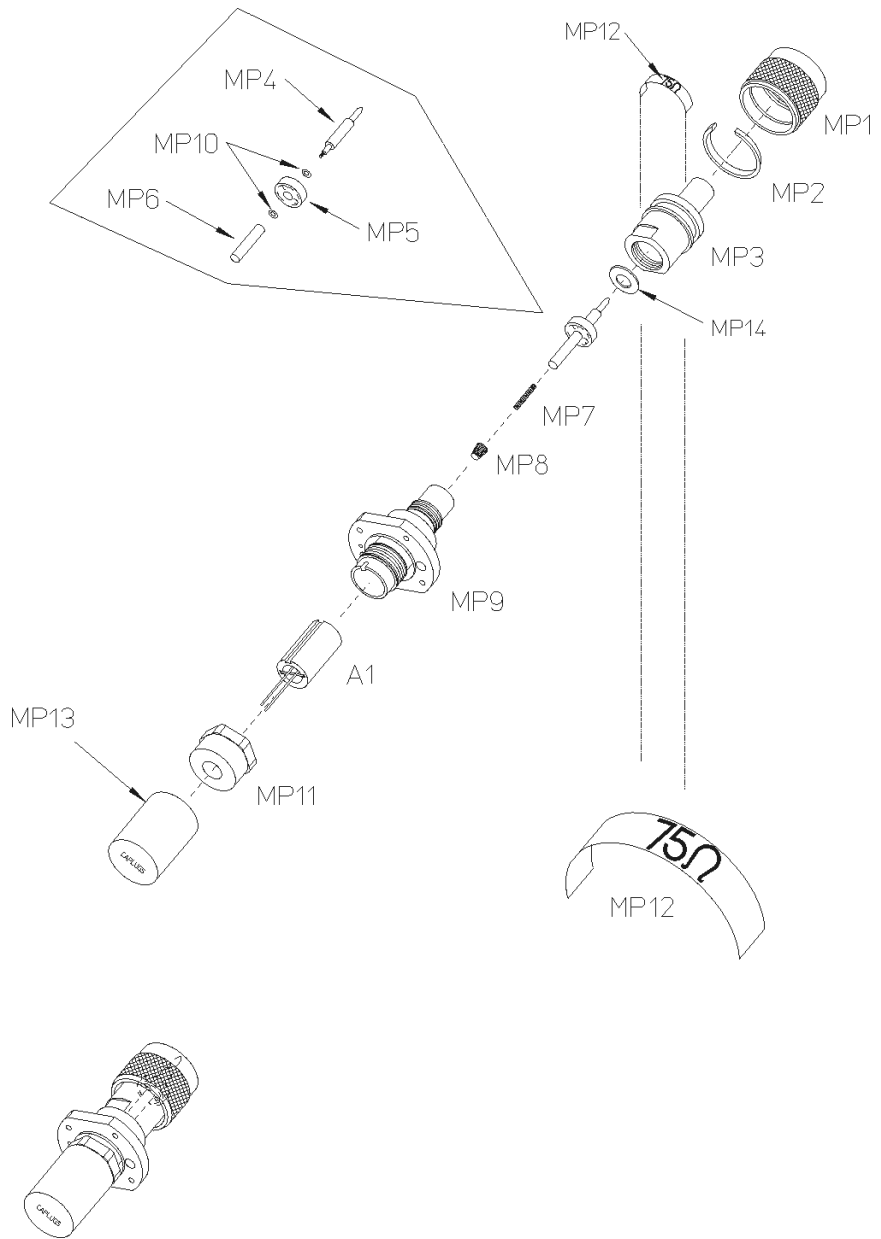
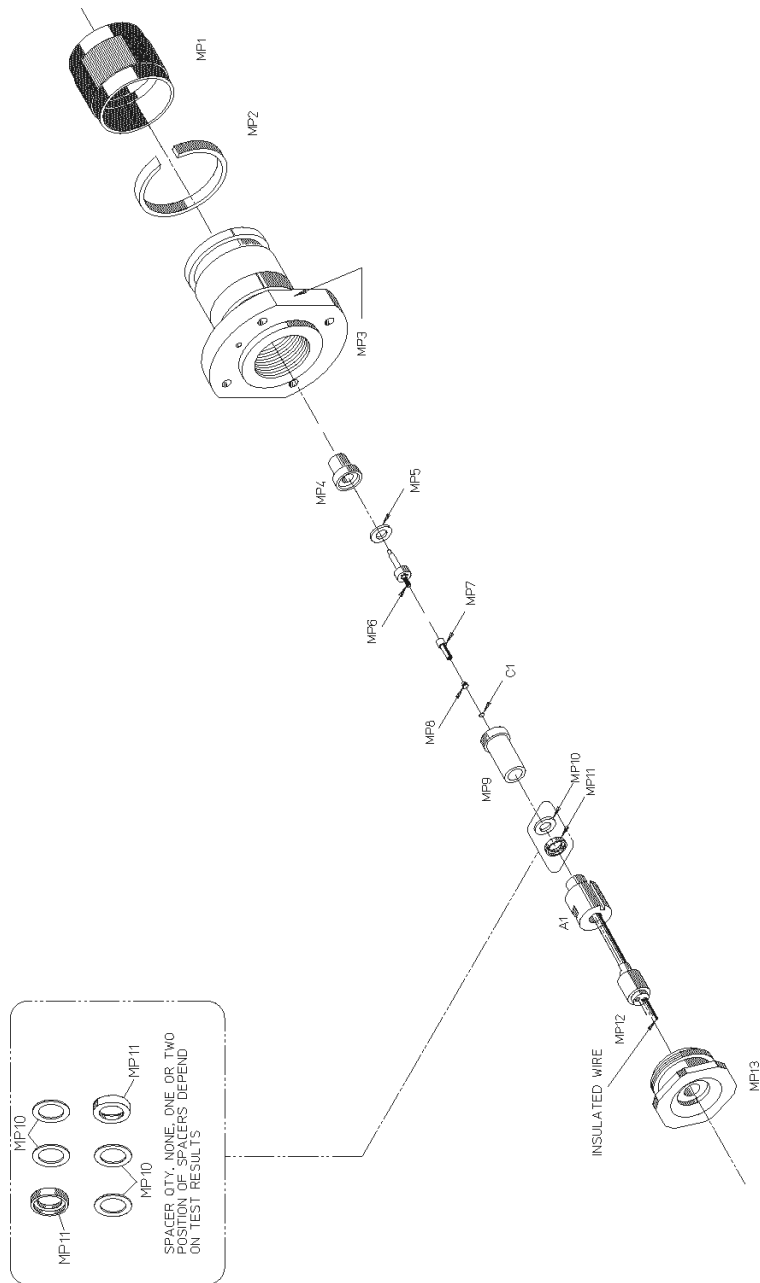

Figure B-7 8485A, 8485A Opt 033, 8485D, and 8485D Opt 033



Bulkhead Assemblies  
Bulkhead Exploded Graphics

Figure B-8

8487A and 8487D

